

# Development of Solar Intensity Radiance Data Acquisition

Ogunkeyede O.Y<sup>1</sup>, Ekundayo O.T<sup>2</sup>, Komolafe T.A<sup>3</sup>

<sup>1</sup>Department of Electrical/Electronic Engineering, Ajayi Crowther University, Oyo, Nigeria.

<sup>2</sup>Raw Materials Research and Development Council Abuja, Nigeria

<sup>3</sup>Federal Polytechnic Ile Oluji, Ondo State.

**Abstract:-** Accurate monitoring and measurement of solar photovoltaic panel parameters are important for solar power plant analysis to evaluate the performance and predict the future energy generation. There are always challenges of getting such data due to huge amount of money to be spent on state of the art equipment or the purchase of reliable satellite weather data. This study aimed at the development of a cost-effective parameter-measuring and logging system for solar photovoltaic system. A PIC Microcontroller, Liquid Crystal Display, 10W Solar Panel, Real-time Clock, and analog processing circuit are the essential parts of the developed solar data logger. The system measures various parameters, including voltage, current, light intensity, together with date and time. Current sensor and voltage sensor were integrated on data logger board to measure parameter that affected efficiency of PV system. The accuracy of the developed system was determined by comparing the measured parameters with that of conventional standard measuring instruments which shows good agreement. One of the benefits of the data logger is the ability to automatically collect and store data over a long period of time. The data can be plotted into V-I graph and P-V graph for analysis. The developed data logger can be used as portable recorder to compare the solar power in different area at specific time and seasons.

**Keyword:-** Solar irradiance, Logging, Microcontroller, Display, RTC.

## I. INTRODUCTION

### ➤ Background of the Study

Serious interest in solar energy production and utilization was prompted after the world energy crisis associated with the 1973 Middle East war. This interest was further fuelled by world apprehensions over nuclear wastes and nuclear safety on one hand and green house gases and global warming on the other (Kornelakis, *et al.* 2009). These considerations make solar energy the best strategic choice as a source of world energy.

Solar energy research emphasizes over the past three decades were concentrated on two main areas. The first is concerned with solar energy direct heat production. The second is concerned about solar energy electricity production. In many research works concerned with effectiveness of the solar film, light intensity measurement,

solar radiation measurement, optimal incident angle for the solar panel and effectiveness of sun's transmission through materials, there is a need for a measuring device that be used to measure solar power.

### ➤ Aim of the Project

The aim of this project is to develop a system that can be used to monitor quantity of available solar power (in  $W/m^2$ ) available at a given time over a square meter of surface.

### ➤ Objective of the Project

The main objectives of the research work are:

- To design a device that can measure, store and display solar Irradiance level in  $W/m^2$  on LCD.
- To develop a system that will be reliable by using firmware-driven metering engine interfaced to very simple circuits; with the monitoring and display handled by firmware.
- To build a low cost device where most of the materials used could be sourced locally.
- To develop a flexible measuring device that can be easily upgraded to incorporate new features as microprocessor is used.
- To develop convenient measuring device that needs no adjustment, and display measured quantities clearly.

### ➤ Areas of Application

Typical applications for the Solar Irradiance measuring device include:

- Solar radiation measurement.
- Transmission measurement that is suitable for measuring the effectiveness of the solar film.
- Car windows light intensity measurement.
- Optimal incident angle for the solar panel.
- Measurement of the sun's transmission through transparent and film glass.

## II. LITERATURE REVIEW

Photovoltaics (PV) is a solid-state, semiconductor-based technology that converts light energy directly into electrical energy, without moving parts, without noise, and without emissions. In 1839, a young French experimental physicist named Edmund Becquerel discovered the photovoltaic effect. While working with two metal electrodes in an electricity-conducting solution, he noted that the apparatus generated an increased voltage when exposed to light. Through the end of the 1800s, a number of researchers, including the likes of Werner Siemens and others, held out great hope for the potential benefits of generating electricity with photovoltaics, even

though many of them were working with selenium (Wiloughby Smith, 1873; Charles Fritts, 1880), which converted less than 1% of the incident light to electricity. However, these researchers had to overcome a credibility problem, as claims for photovoltaics appeared to violate the known laws of physics at that time.

### ➤ Characteristics of a Solar Cell

The performance of a solar cell is best indicated by the current voltage characteristics. It is therefore important to know the output voltage (V) and the output current (I) and how they vary with respect to each other.

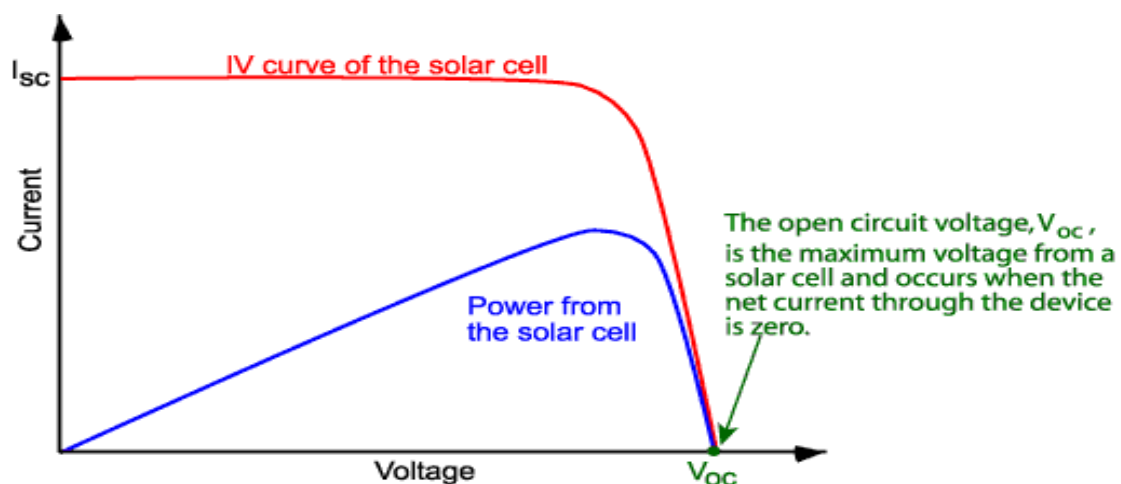

Fig 1 The Characteristic I-V Curve for Solar Cells (Honsberg et al.,2010)

### ➤ Factors which Affect the Performance Of Solar Cells

#### • Temperature

As the temperature of a solar cell increases the open circuit voltage  $V_{oc}$  decreases, but the short circuit current increases marginally. The combined effect is a decrease in power. As a rule of thumb, the output power of crystalline panels changes by 2.5% for every 5°C variation in temperature. The output power of Thin Film panels changes 0.5% for every °C variation in temperature.

#### • Irradiance

As the irradiance varies there is an almost linear variation of the short circuit current. The open circuit voltage, however, does not change dramatically. Available Solar Irradiance at a given location depends on geographical coordinates (Latitude), time of the day, season, altitude above sea level, and inclination of the surface.

#### • Fill Factor

The fill factor is a reflection of how much series resistance and how little shunt resistance there is in a solar cell and its circuit. The fill factor is the ratio of maximum power to the product of  $I_{sc}$  and  $V_{oc}$  and is an operating characteristic which indicates the performance of a cell.

Decreases in fill factor may indicate problems with the cell.

$$\text{Fill Factor} = FF = I_{mp} \times V_{mp} / I_{sc} \times V_{oc} = P_{max} / I_{sc} \times V_{oc}$$

A more important use of the fill factor is to determine the performance of the module in poor irradiance conditions. If the fill factor is high then this implies that I - V curve for that module is quite square. If the fill factor is low, when the irradiance is low the characteristics of the module indicate that there would be no charging of the battery because the voltage would not be in the required range for battery charging.

### ➤ Review of Related Works on Solar Data Logger

Today, solar technology is powering diverse applications—from the world's communications networks, through its use in satellites, repeater stations, and remote power supplies for communications appliances, to grid-tied homes and commercial buildings, to rural and remote lighting and water pumping systems.

Energy from the sun arrives at the earth's surface at peak value of about 1.kW / m<sup>2</sup> and 1.2kW / m<sup>2</sup> at the Equator. The amount of solar power available per unit area is known as the irradiance. Irradiance is normally measured with the aid of pyranometer or reference solar cells (Kornelakis and Koutroulis, 2009). Irradiation is the total quantity of radiant solar energy per unit area received over a given period, eg monthly or annually. Daily irradiation is

commonly referred to as *daily peak sun hours*. Most of findings on available Solar Data Logger are mainly commercial modules such as SOLAR-100 made by Amprobe Test Tool which measures solar output that is used to calculate overall energy, efficiency and placement of solar systems.

### III. METHODOLOGY

#### ➤ System Architecture

Various samples over the PV input were taken using Analog to Digital Converter (ADC) of the microcontroller. The sampled signals were digitized, and different calculations were performed on this digitized signal. Figure 2 shows the basic block diagram of the solar data logger.

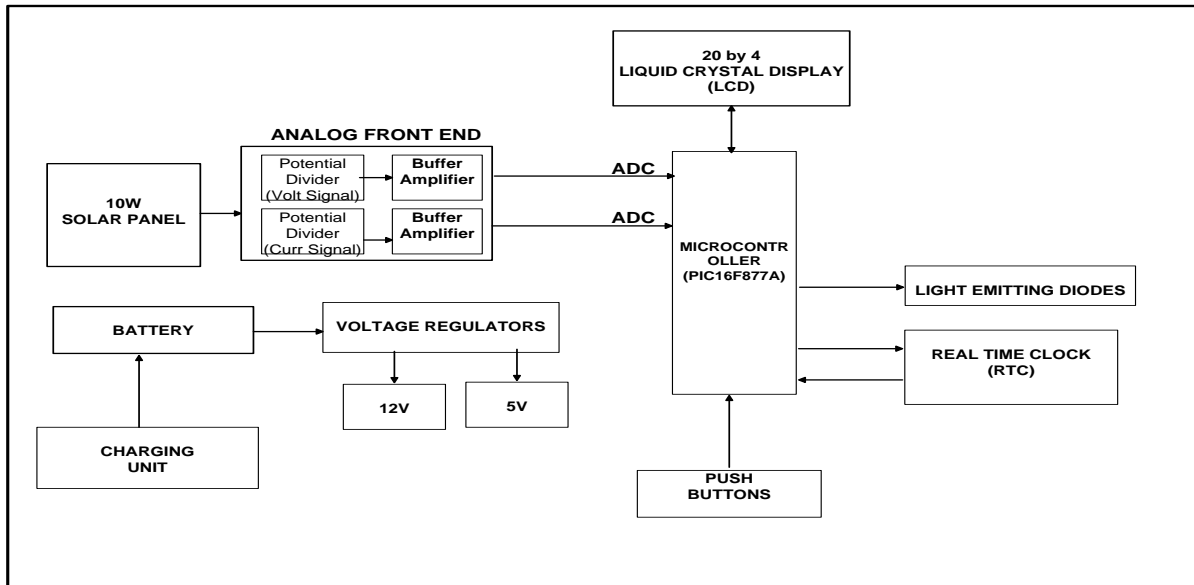

Fig 2 Basic Block Diagram of the System

This system consists of three main sub-units as follows:

- Data acquisition
- Data Processing
- Display

#### • Data Acquisition

Data acquisition comprises scaling, sampling and analog-to-digital conversion. For this purpose, the in-built Analog-to-Digital Converter of PIC16F876A is used. Two ADC channels are used from the PIC16F876A for acquiring the solar panel open circuit voltage, and output current when a load resistor is connected to the panel's output.

#### • Data Processing

Data processing describes a number of calculations on the data acquired to get the required parameters. For this we are using the RISC architecture based 8 bit microcontroller PIC16F876A by Microchip. The chip is programmed to perform various tasks such as calculating the parameters and store the same in the on-chip memory. The microcontroller equally reads the time and date from the system's RTC. The

acquired data is then time-stamped and store inside the microcontroller's EEPROM. The data can be retrieved from the EEPROM at any time.

#### • Parameters Display

Intelligent 20-by-4 lines LCD display is used to display different solar parameters which are as follows: PV open circuit Voltage, Instantaneous Solar Power, Maximum Solar Power, Minimum Solar Power and Real Time Clock (Date and Time).

#### ➤ Hardware

The microprocessor (PIC16F876A) forms the heart of the system. The microprocessor interfaces to the analog front-end where solar panel output voltage and current are scaled, sampled and digitized. The analog front-end consists of the signal capturing block, which uses a number of analog devices like op-amps and passive components like capacitors, resistors etc. A 20-by-4 lines LCD is interfaced to the microprocessor via a dedicated parallel port to display the measured solar parameters, time and date.

• Voltage Sensing Circuit

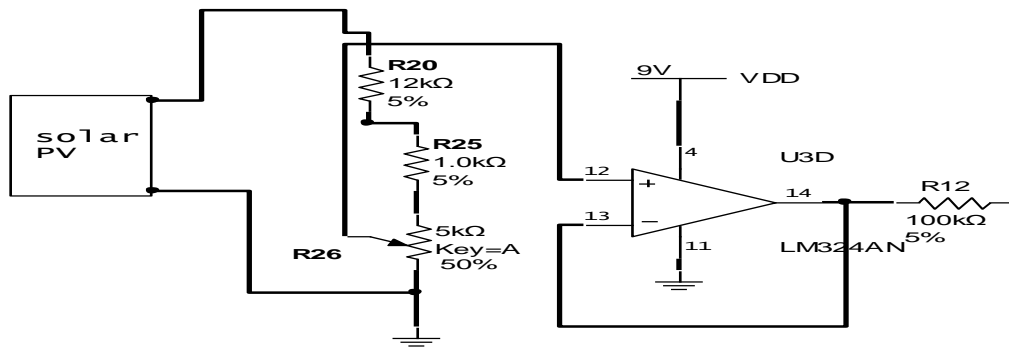

Fig 3 Voltage Sensing Circuit

A solar panel with nominal voltage of 12V is selected as this is what can be obtained in the market. This panel can give open circuit voltage of 18V at peak solar radiation. Scaling down to lower value, A Voltage dividing network (R25, R26 and R20) is employed. R26 is a variable resistor that allows calibration of measured voltage. R20 (12KΩ) is selected (any value can be selected, only that it should not be too high > 100KΩ and should not be too low < 1KΩ);

When R26 = 0, Sampled Voltage =  $R25 / (R25 + R20) \times 18\text{volts}$

=  $2.2 / (10 + 2.2) \times 18\text{ volts} = 3.2\text{Volts}$ . This value is far below the maximum voltage of 5.0V expected at the input pin of the microcontroller.

The output of the potential dividing network is connected to input of an OP-amp, configured as unity-gain voltage buffer circuit. This is necessary in order to reduce the impedance at the input of ADC circuit of the microcontroller.

• Analog-To-Digital Conversion

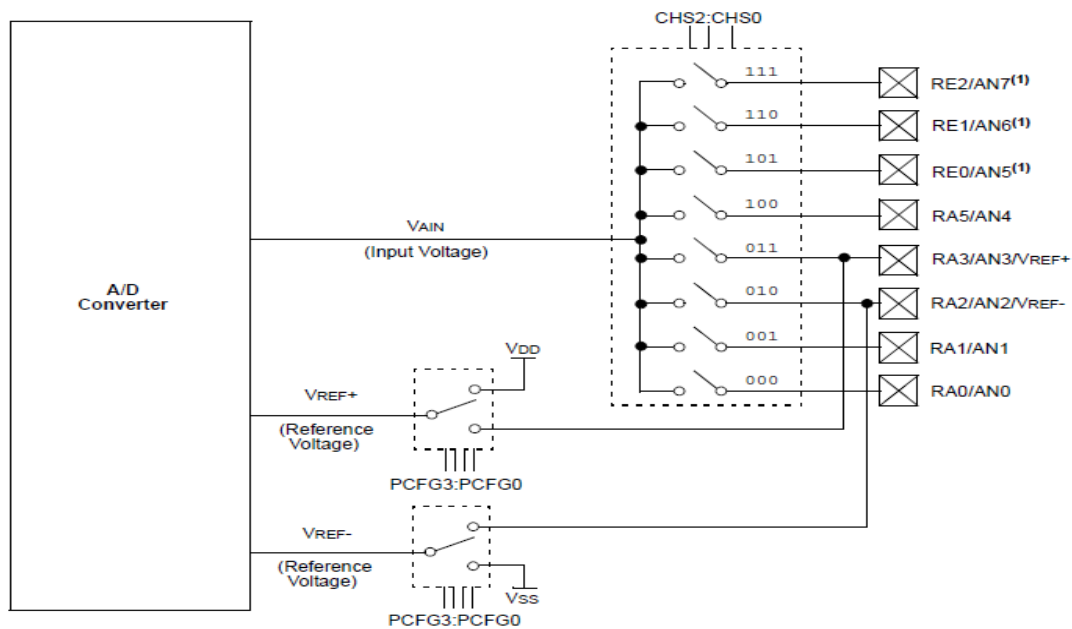

Fig 4 A/D Block Diagram of PIC16F876A

The conversion of an analog input signal results in a corresponding 10-bit digital number. The A/D module has high and low-voltage reference input that is software selectable to some combination of VDD, VSS, RA2 or RA3. The A/D converter has a unique feature of being able to operate while the device is in Sleep mode. To operate in Sleep, the A/D clock must be derived from the A/D's internal RC oscillator. Clearing the GO/DONE bit during a

conversion will abort the current conversion. The A/D Result register pair will NOT be updated with the partially completed A/D conversion sample. That is, the ADRESH:ADRESL registers will continue to contain the value of the last completed conversion (or the last value written to the ADRESH:ADRESL registers). After the A/D conversion is aborted, the next acquisition on the selected channel is automatically started.

• *Power Supply Design*

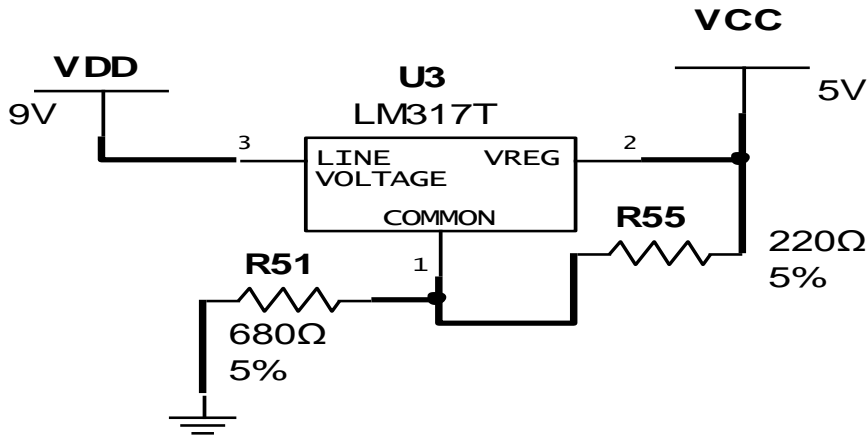

Fig 5 System 5V Power Supply

LM317 is used as Positive regulator; while resistors R51 and R55 form the Output Voltage Selecting component. Using the Formula:

$$V_{out} = 1.25(1 + R51/R55) = 1.25 (1 + 680/220) = +5.11 \text{ Volts.}$$

• *Solar Data Logger*

A Complete Circuit Diagram of Solar Data Logger is shown in Fig 6.

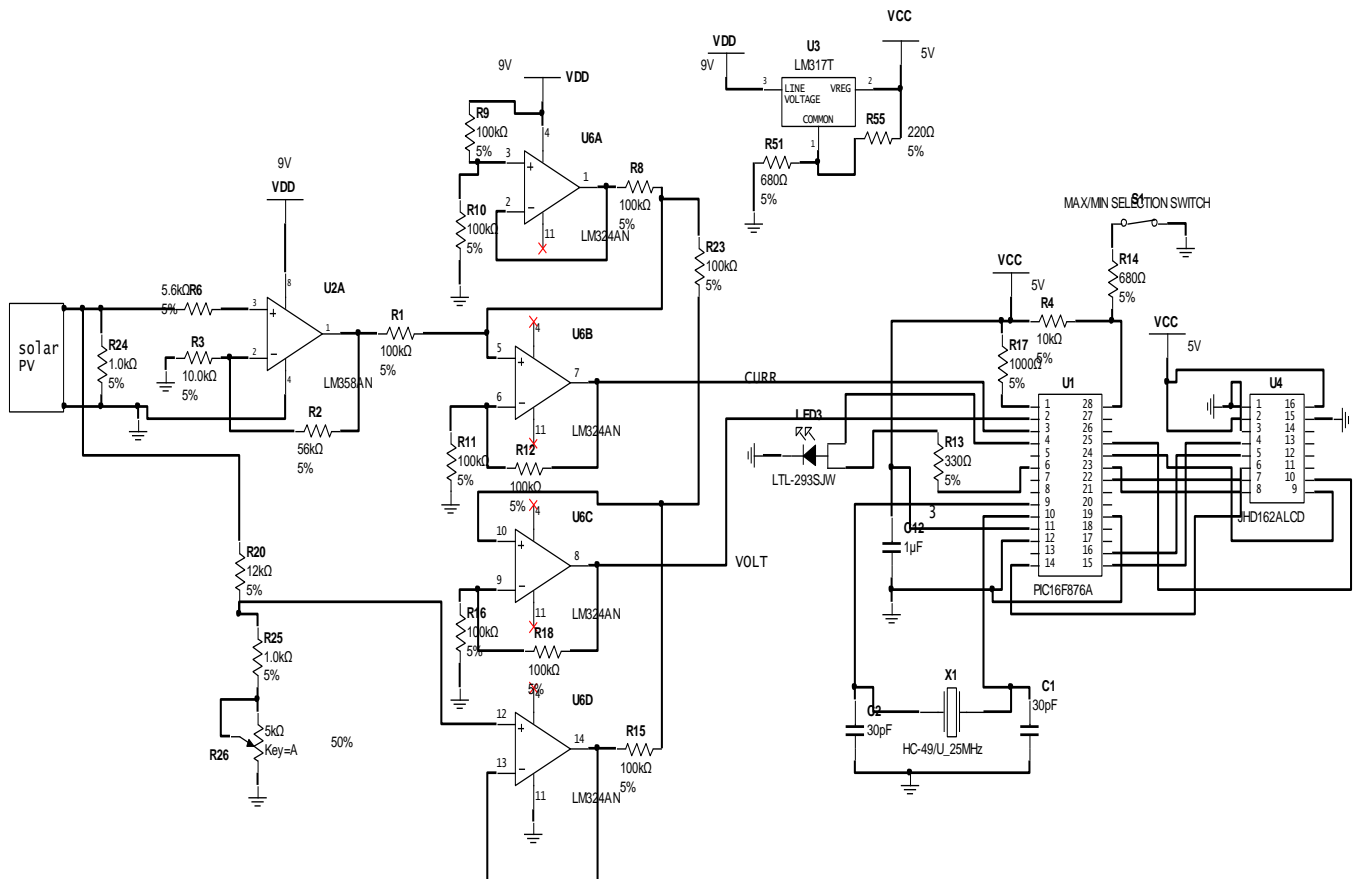

Fig 6 Complete Circuit Diagram of Solar Data Logger

➤ *Firmware Development*

The software is divided into small independent modules. The modules are written in assembly language for the PIC16F876A.

• *Firmware Algorithm*

The flow chart shown below depicts the overall functions of the Solar Data Logger:

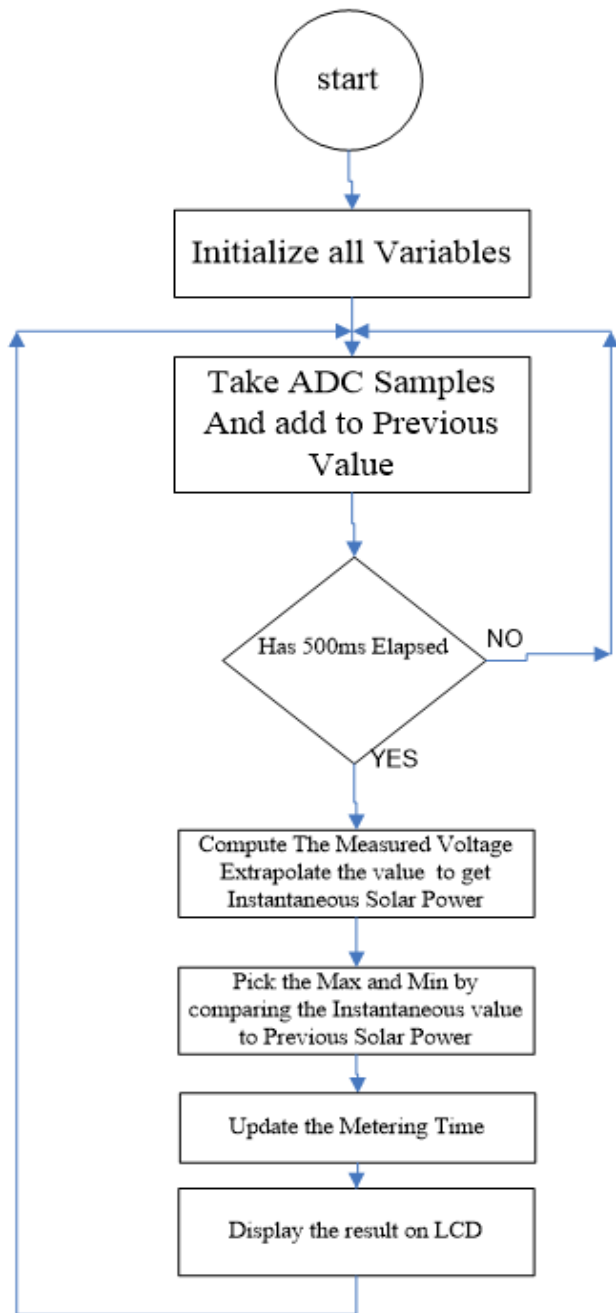

Fig 7 Flowchart of Solar Data Logger

• *Implementing an Embedded System Design*

A development system for embedded controllers is a system of programs running on a desktop PC to help write, edit, debug and program code - the intelligence of embedded systems applications - into a microcontroller. A typical embedded systems application runs on a PC and contains all the components needed to design and deploy embedded systems.

The typical tasks for developing an embedded controller application are:

- *Create high level design:* From the features and performance desired, decide which Microcontroller Unit or Digital Signal Processor device is best suited to the application, then design the associated hardware

circuitry. After determining which peripherals and pins control the hardware, write the firmware - the software that will control the hardware aspects of the embedded application. A language tool such as an assembler, which is directly translatable into machine code, or a compiler that allows a more natural language for creating programs, should be used to write and edit code. Assemblers and compilers help make the code structured, allowing function labels to identify code routines with variables that have names associated with their use.

- Compile, assemble and link the software using the assembler and/or compiler and linker to convert code into "ones and zeroes" - machine code for the MCUs. This machine code will eventually become the firmware (the code programmed into the microcontroller).
- *Test the code:* Usually a complex program does not work exactly the way imagined, and "bugs" need to be removed from the design to get proper results. The debugger allows one to see the "ones and zeroes" execute, related to the source code written, with the symbols and function names from your program.
- "Burn" the code into a microcontroller and verify that it executes correctly in the finished application.

➤ *Construction*

The programmed microcontroller was tested in a breadboard with its associated sensing/control circuits. Extensive tests were performed on all the components used in each of the subsystems to ensure that they are working reliably.

Having worked satisfactorily, the microcontroller and the associated components were then transferred and soldered; and the entire board was properly connected to accessories. The whole arrangement was then housed in a durable plastic enclosure. The device was constructed in such a way that usage is very simple.

**IV. RESULTS AND DISCUSSION**

➤ *Constructed Solar Data Logger*

The picture of the developed solar data logger is shown in Fig. 8 below.

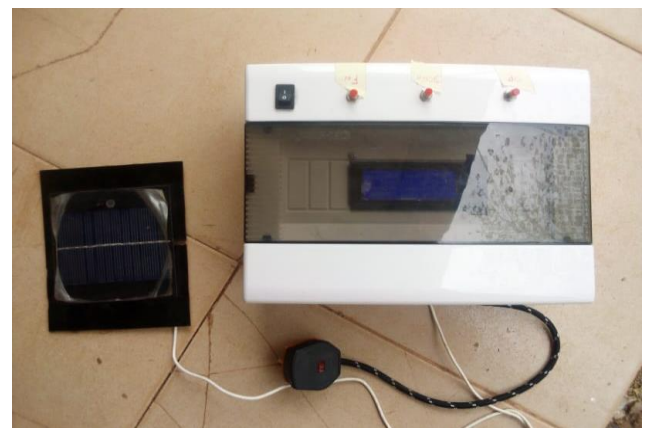

Fig 8 External View of the Developed Solar Data Logger



### ➤ Solar Data Results

The Solar data Logger was used to capture solar power obtained on a typical day in Esa-Oke, Osun State, Nigeria. The results obtained are shown in Table 1 below.

Table 1 Irradiance Values on a Typical Day in Esa-Oke

Time of the day	Irradiance (W/m <sup>2</sup> )	Time	Irradiance (W/m <sup>2</sup> )
06:00AM	80	01:00PM	1200
07:00AM	400	02:00PM	1100
08:00AM	500	03:00PM	700
09:00AM	600	04:00PM	600
10:00AM	700	05:00PM	400
11:00AM	1000	06:00PM	200
12:00PM	1200	07:00PM	150

## V. CONCLUSION

It can be concluded that the goal and preliminary objectives of designing and constructing this **Solar Data Logger** were met. The various tests carried out and the results obtained demonstrate that the aims and objectives of developing the Solar Data Logger are achieved. The system worked according to specifications, and quite satisfactorily. The system is relatively affordable, reliable, and easy to install.

## FUTURE WORKS

Future research works will consider incorporation of remote monitoring system into the solar data logger. Internet-of-things, Zigbee and LoraWan are some of the wireless communication medium that will be explored. A Solar Data Logger interfaced with remote monitoring system will allow real-time monitoring of the solar data at a given date and time with convenience.

## REFERENCES

- [1]. Ahmad, G. E. and Hussein, H. M. S. Comparative study of PV modules with and without a tilted plane reflector. *Energy Conversion and Management*. 07 2001, pp. 1327-1333.
- [2]. Chowdhury, S.A., Sarwar, A.T.M.G. and Khan, M.R. Optimized Solar Home System package design: Bangladesh perspective, art. no. 5454199. *Proceedings of 1st International Conference on the Developments in Renewable Energy Technology, ICDRET 2009*. 12 2009, pp. 148 - 152.
- [3]. Digital Power Meter Manifold, Chung-Ping Young and Michael J. Denaney, IEEE Instrumentation and Measurement Technology Conference, Ottawa, Canada, May 19-21, 1997
- [4]. The 8051 Microcontroller, Architecture, Programming and Application, Kenneth J. Ayala
- [5]. Elektor/Electronics BV (1995). Build Your Own Electronic Test Instruments, Tech Publications PTE Ltd, Singapore
- [6]. European Commission. Photovoltaic Geographical Information System - Interactive Maps. *PV potential estimation utility*. [Online] [Cited: 08 11 2010.] <http://re.jrc.ec.europa.eu/pvgis/apps3/pvest.php?map=africa&lang=en>.
- [7]. Guekos, A. Heinämäkia and G. Solar cell short-circuit current dependence on the angle of the incident radiation. *Solar cells*. 02 1987, pp. Volume 20, Issue 1, Pages 65-73.
- [8]. Khatib, Tamer. A review of designing, installing and evaluating standalone photovoltaic power systems. *Journal of Applied Sciences*. 2010, pp. Volume 10, Issue 13, 2010, Pages 1212 - 1228.
- [9]. Pidwirny, Michael. Solar Radiation. *The Encyclopedia of Earth*. [Online] 01 24, 2010. [Cited: 11 08, 2010.] [http://www.eoearth.org/article/Solar\\_radiation](http://www.eoearth.org/article/Solar_radiation).
- [10]. SolarServer. Photovoltaics: Solar Electricity and Solar Cells in Theory and Practice. *SolarServer*. [Online] 26 08 2010. [Cited: 11 11 2010.] <http://www.solarserver.com/knowledge/basic-knowledge/photovoltaics.html>.