

# Automatic Electric Vehicle Charging Station

Jayen Modi<sup>1</sup>

Department of Electronics and Computer Science  
Fr. Conceicao Rodrigues College of Engineering  
Mumbai, India

Shalom Richard Pakhare<sup>2</sup>

Department of Electronics and Computer Science  
Fr. Conceicao Rodrigues College of Engineering  
Mumbai, India

Abhishek Athani<sup>3</sup>

Department of Electronics and Computer Science  
Fr. Conceicao Rodrigues College of Engineering  
Mumbai, India

Rizwan Baig<sup>4</sup>

Department of Electronics and Computer Science  
Fr. Conceicao Rodrigues College of Engineering  
Mumbai, India

Siddarth Mhade<sup>5</sup>

Department of Electronics and Computer Science  
Fr. Conceicao Rodrigues College of Engineering  
Mumbai, India

**Abstract:-** Our Automatic Electric Vehicle Charging station is a autonomous power supply unit which works without the need for human attendants. The system is designed to facilitate the existing power grid infrastructure. The system employs the Raspberry Pi as our primary controller board and hosts the User Interface on the LCD Display mounted on the Charger Housing. The Pi Board interfaces with our custom Pilot PCB to communicate with the Electric Vehicle Battery Management Systems to negotiate the charging speed, capacity of the car battery and perform safety checks. The user can choose AC level 1,2 or DC level 3 charging. the system uses a 30A relay circuit to isolate the battery from the power supply until all the necessary checks and payment processes are completed. RazorPay is our real time Payment gateway for payment transactions. Once the user has completed the formalities the charging process will begin. we also have a charging monitoring system developed that will help users track the battery charge percentage and charging time remaining on the LCD display. The station has emergency Kill Switches and Emergency Stop buttons mounted on the housing to address safety concerns that arise on the advert of damaged high power output utilities, when engaged the entire system will kill all the power inputs from the grid so that any fault can be safely repaired without risk of electrocution. For our implementation and testing we have built a 18650 NMC chemistry 3S5P Battery pack with a 3S BMS. the unit utilizes level 3 AC charging SAE(Society of Automotive Engineering) standards to ensure the safety and quality of the service.

**Keywords:-** Electric Vehicle, Battery, Battery Charging, Alternating Current Charging, Direct Current Charging, Lithium Ion cells, Charging Station, J1772, Battery Management System, Battery Monitoring System,

## I. INTRODUCTION

### A. Overview

#### ➤ Battery Topologies:

Electric vehicles are powered by large battery packs which are made up of small Li-ion cells, these cells have very specific chemistries (eg NMC, LFP, LiPo) and topologies that needs to be taken into account while designing the charging system for the battery [8]. The internal cells are arranged in a combination of series and parallel to meet the desired criteria, the cell arrangements are subject to their sizes, the most common cell sizes are 21700, 185650 and 26650, the cells are arranged in a manner that results in efficient cooling of the pack and protection from damage in case of a collision.

#### ➤ Ac Charging:

As mentioned earlier various factors concerning the battery pack need to be taken into consideration while designing a charging system for the same, in order to maximize the compatibility of the battery and the charger various manufacturers choose to install an on-board charger inside the vehicle, this allows them the freedom to design their own battery topologies also ensures that the charger they implement is optimized for their battery pack [6]. The use of on-board chargers necessitate the BMS to continuously monitor the battery and charging process. this type of charging topology needs a input AC supply. AC charging guarantees prolonged battery health. the only disadvantage is the amount of time taken per charge [8].

#### ➤ Dc Charging:

In many modern electric vehicles DC fast charging is becoming a very common occurrence. DC charging is a technique in which the charger bypasses the BMS and the on-board charger to directly charge the battery pack with Direct supply, this technique relies heavily on battery and charger topology standardisation as there is no protection as compared to AC charging [2]. DC charging relies on

techniques such as CC/CV algorithms to charge the car faster while protecting the internal chemistry of the pack. DC charging is very fast as compared to AC charging but over a longer duration of time can cause damage to battery health as the charger and battery pack have different manufactures and thus are not optimized for each other [1].

**B. Bms - Battery Management System**

The battery management system is what communicates with the charging station and provides verification of a proper connection. the primary function of the BMS is to ensure that all the cells in the battery pack are at the same voltage level at all times including charging and discharging. the BMS is the primary controller for all operations that are battery related [8].

It performs the task of requesting charge from the station and routing the charge to the individual cells in the pack. The BMS must remain connected to the charging station during the entire charging process. it also performs safety functions such as the diode check and auto cut-off in case of any unexpected occurrence.

**C. Payment and Charging Process**

The charging station operation begins when it is connected to the electric vehicle by the user, if not connected or disconnected the station UI will not progress to the next page. Once plugged the Pilot communication protocol begins. the diode check is performed ensuring that a genuine vehicle is connected for charging. after the needed checks are performed the station UI is now accessible [3].

The user must now enter the requested details and the type of charging they prefer (AC charging or DC charging) after the payment process is completed via the razorpay client the status is verified and charging process begins by closing the AC or DC relay respectively, the timer begins according to the payment amount and charging continues till the timer ends or is interrupted. After the charging is done the invoice is sent to the user and a copy is stored in the system as well for verification and book keeping.

**D. Safety Features**

The station is protected by a number of hardware circuit breakers and software interrupts. the primary input is protected by a surge detecting MCB rated for 30A. All the components used are rated for 230V 30A. The station housing consists of 2 buttons which are the Emergency Kill switch and the stop charging button [1].

The kill switch shuts down the power for the entire unit and also sends a maintenance request to the owner of the station as well as the responsible engineer. The stop charging button simply terminates the charging process while the station remains on and functioning.

**E. Motivation**

As the demand for EVs in India is increasing but the supporting infrastructure for powering EVs is not keeping up with the high demand. Our EV charging station provides a cost efficient solution to the problem. our stations are compact can

be installed in commercial spaces and parking lots, even in private residences [2].

The automatic EV charging station offers solutions to many problems that may affect a EV user. the Owners of such stations will also stand to benefit from installing these systems which ensures a large number of installations in turn granting access to charging for EV users in public and commercial spaces [4].

**II. LITERATURE REVIEW**

**A. Smart Charging of Electric Vehicle**

The paper summarizes that Electric vehicles (EVs) have become increasingly popular and prominent as a transportation solution, but opportunities to recharge the vehicle far away from home have become a critical issue. Wireless charging EVs could be a type of EV that uses wireless power transfer (WPT) technology to transfer electrical energy without physical contact. The paper further describes Faraday’s law in detail. WPT is the transmission of electricity from the power supply to an electrical load without employment of any physical connectors. The proposed system is activated. The battery is connected to the second coil within the EV and thus, the battery gets charged. This technology is new and a very easy way to charge the vehicle but becomes impractical considering the costs of building, developing and maintaining such a system in real life. the paper provides us with a useful block diagram shown in figure II-A as the recommended charging equipment standard which optimizes safety and efficiency. [1]

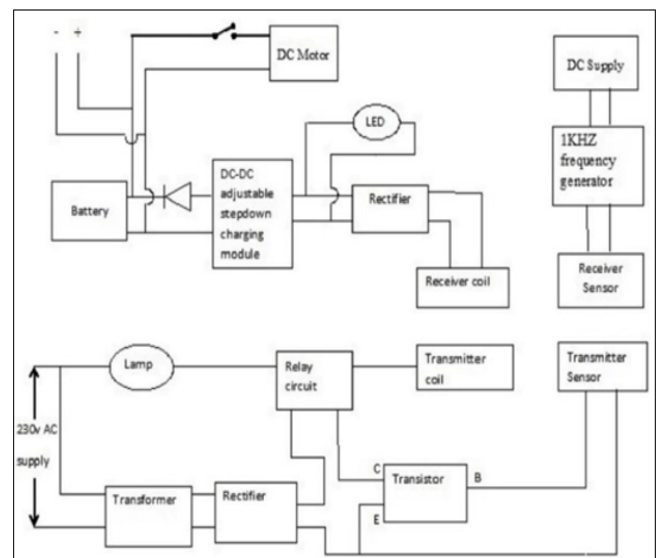

Fig 1 Proposed Block Diagram of Smart Charging For Electric Vehicles

**B. Locating Multiple Size and Multiple Type of Charging Station for Battery Electricity Vehicles**

In recent years, Battery Electric Vehicles (BEVs) have developed rapidly due to the serious environmental pollution and the huge energy consumption of fuel vehicles. With the improvement of people’s environmental awareness and the strong support from the government, many companies began

to develop and use BEVs. BEVs have many advantages over motor vehicles, such as being comfortable, safe, convenient in operation, noise free and possessing a long service life. However, there are reasons why BEVs have not been popularized so far, such as the limited battery capacity and limited driving range. Nowadays, with the improvement of technology, fast charging techniques are already well developed, such as the CHAdeMO standard (CHAdeMO) and the Combined Coupler Standard (CCS).

Fast charging can charge up to 80 percent of a vehicle's rated battery capacity within 0.2 to 1 h, while slow charging can take 10 to 20 h for full charge. Therefore, the government should set up different sizes and types of charging stations to meet different needs of travelers. [2]

#### C. Unified Payment Interface (UPI) - a way Towards Cashless Economy

India has made slow but steady progress in E-Payments, such as UPI (Unified payment Interface). India started NPCI (National Payments Corporation of India) in 2009, which controls all E Payments in India and is setup with the Reserve Bank of India (RBI) and Indian bank association (IBA). NPCI has taken many steps to simplify and provide a single interface payment system across all the systems. The most important details in this text are that the system should be universal and allow for full interoperability between multiple identifiers such as Aadhaar number, mobile number, and new virtual payment addresses.

The main and most needed thing is that the end to end protection between sender and receiver should be more, data reading from smart phone to server should be strongly encrypted, and the process of sending money or receiving should not be complicated due to security reasons. Additionally, the solution should offer a mechanism to take full advantage of the 150 million smartphone users today and that number is expected to grow to 500 million in the next 5 years, allowing banks and other payment players to focus on core business and allow half a billion phones to be the primary payment device in conjunction with other 3rd party authentication. [3]

#### D. Impact of Smart Charging for Consumers in a Real world Pilot

This study observes Electric mobility, as it is developing rapidly, with market shares for electric vehicles increasing beyond niche markets in leading countries. Worldwide the market growth has been higher than 30% for five consecutive years, leading to an accumulated number of 5 million EVs on the road by 2019. The study discusses the need for phenomenon like /Smart charging which is the process where charging of an EV is varied on two dimensions current levels offered at the charging station. It is considered to optimize the effect on objectives such as reduction of net impact by EVs, minimizing energy costs, or matching with renewable energy generation. Simulation models have been applied to analyze effects of smart charging on grid impacts, energy market prices and matching of renewable energy profiles.

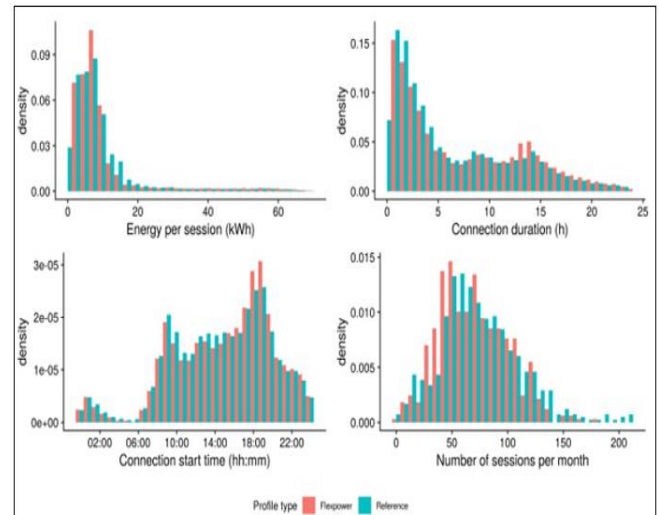

Fig 2 Customer Reception of Smart charging

Electricity costs for charging EVs can be reduced in the range of 10–50% by applying smart charging, which largely depends on local energy market conditions and the characteristics of the applied smart charging profiles. Smart charging is a strategy that can be applied to increase the match with renewable energy generation and to stimulate users to allow for rescheduled charging. Studies have shown how smart charging can be applied to increase the match with renewable energy generation, while incentives can be applied to stimulate users to allow for rescheduled charging. However, studies often lack real-world data on actual charging speed and tend to underestimate factors such as double-occupancy (two vehicles on one charging station) and differences in charging speeds between EV models. Additionally, EV models differ significantly in charging speeds, which influences the impact of varying charging currents.

#### E. Modeling and Control of the PFC Stage for A 50KW EV fast Battery Charger

The traction battery (typically of the lithium-ion type) is the most critical component of an electric vehicle (EV). There are two types of battery chargers: the on-board (sometimes called slow or low power) charger and the off-board (so-called fast or high power) charger. The typical concept of EV includes urban driving only, where the full battery charge is sufficient for short-range routes. Recently, a paradigm shift towards closing the gap between EV and conventional vehicles has occurred, forcing the infrastructure to support EV intercity driving. The concept of Battery Switch Station (BSS) was developed: when out of charge, the EV battery can be replaced at a BSS, allowing nearly uninterrupted long range driving.

The FC is basically a controlled AC/DC power supply, drawing the power from the three phase AC utility grid and injecting it into the traction battery. The FC must satisfy both the grid code in terms of THD and power factor from the utility side and lithium-ion charging modes from the battery side. The FC usually performs rectification and Power Factor Correction (PFC) according to regulation requirements. It can be accomplished either by employing an active rectifier, or a

diode rectifier combined with a PFC circuit. The well-known single phase PFC approach, where a full-rating boost DC-DC converter follows the diode rectifier, is unsuitable for the three-phase case.

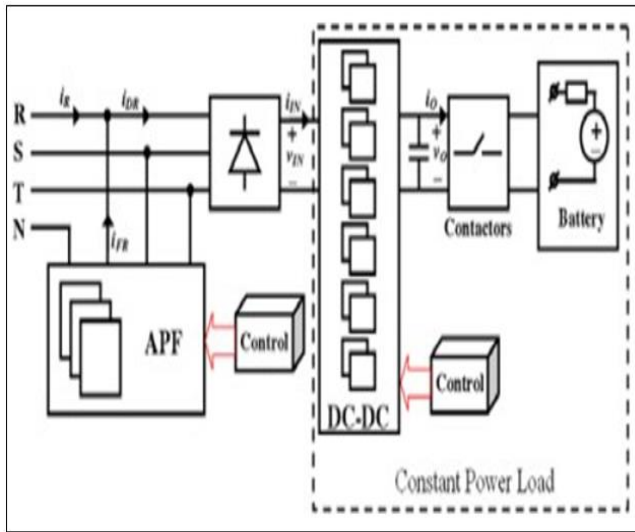

Fig 3 Block Diagram for DC fast charging implementation

Alternatively, a more elegant approach employs a shunt connected Active Power Filter (APF) at the rectifier input, supplying the reactive current to the diode rectifier and thus achieving both near unity power factor and near zero Total Harmonic Distortion (THD). The use of either one three phase or three single phase APF configurations are potentially feasible for implementing a three phase PFC. The additional advantage of the approach is the fact that because of the shunt connection, the APF rating is approximately 40% of the series-connected PFC circuit rating, since the APF supplies the reactive power only to the diode rectifier (which is around 40% of the active power, flowing through the rectifier). The paper describes modeling and control of the PFC stage for a 50KW EV Fast Battery Charger, employing a three phase diode rectifier combined with three single phase APFs as the input stage. The charger operates as a voltage supply with controllable dynamic current limitation and is able to charge lithiumion batteries within the power range of 0 – 50KW by supplying DC current up to 125A. The charger operates from the 380V three phase utility grid and is able to charge lithiumion batteries within the power range of 0 – 50KW by supplying DC current up to 125A. [5]

*F. Smart Level 2 Dc Electric Vehicle Charging Station with Improved Grid Stability and Battery Backup*

The transformation of transportation technologies from conventional to recent ones has occurred in an exponential manner. The automotive industry is one of the largest consumers of fossil fuels, and the use of EVs instead of IC engine driven vehicles is increasing due to the increasing price and decreasing availability of fossil fuels. The pollution rate is less, but it cannot be nil since to generate the electrical energy consumed by the EVs, the generating station will be causing some amount of pollution. To reduce the charging impact on the grid and maintain quality within permissible limits, the charging current can be controlled using different

control techniques like centralized and decentralized control. However, the power quality issues that arise due to charging station loading will remain almost the same.

Another solution is to reduce the charging impact on the grid and maintain quality within permissible limits. EV chargers have protocols to communicate data between vehicle battery and charging station, such as CHAdeMO and SAE J1772. This data includes %SOC, voltage, Ah rating, type of battery etc. The best solution to sudden spike in electric demand is implementing a smart system interaction between the grid and the EV. There are different standards in the market for the design of EV charging stations, such as AC Level 1, AC Level 2, and DC Fast Charging.

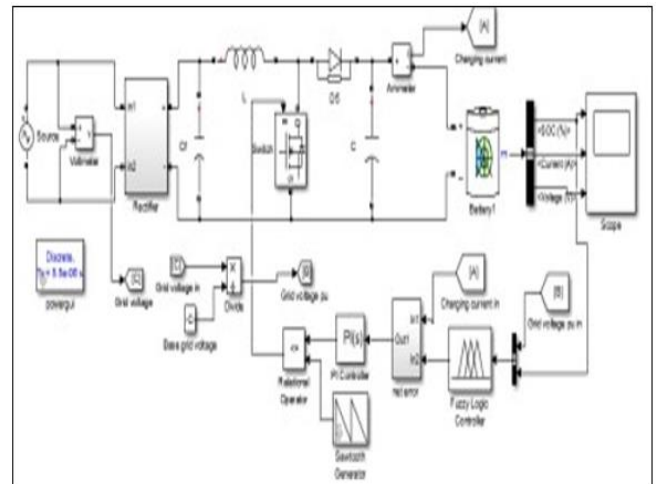

Fig 4 Simulation for Smart DC fast charging

The charger ratings vary with the standard grid supply ratings, with AC Level 1 having single phase 120V system with maximum possible charging current 16A and AC Level 2 having 208-240V split phase system with maximum 30A charging current. This paper presents a customized offboard DC charging station with renewable energy utilization to reduce the cost and improve the charging facility. It is designed for 7.2kW and has been expanded to 32A and 80A, respectively. The peak current capacity has been increased to 19.2kW, but the loss and cost are high. To reduce the cost and improve the charging facility, a customized offboard DC charging station with renewable energy utilization is designed and simulated. Section II presents the overall system description, Section III briefs the customized modes of EV charging, Section IV includes the explanation of designed charging current controller for quick charging mode, and Section V presents the simulation results and the analysis. [6]

*G. Design and Simulation of a Dc Electric Vehicle Charging Station Connected to a mvdc Infrastructure*

The transportation sector currently consumes the vast majority of energy from petroleum, with vehicles with unconventional fuel systems (flex-fuel, diesel, hybrid-electric) making up 15% of new vehicle sales in 2009. To meet this increased penetration of plug-in hybrid electric vehicles (PHEV) and electric vehicles (EV), new infrastructure is required from charging stations to electric distribution. DC systems have been explored in naval ship applications, but

with advances in power electronic technologies and a shifting of loads from AC to DC, electric power sector organizations around the world are exploring a proposed Medium Voltage DC (MVDC). The MVDC concept is a collection platform designed to help integrate renewables and address future needs in the general area of electric power conversion, as well as to serve diverse AC and DC loads. The need for MVDC technology development has been driven by the liberalization of the energy market, which has led to installations of large scale wind and solar farms at the transmission and distribution level.

The penetration of these renewable energy technologies both on-shore and, soon enough off-shore, in the United States is rapidly increasing and will require a DC integration link of some kind. The MVDC platform is an additional layer of infrastructure in the electric grid between the transmission and distribution levels. This paper presents the design and simulation of an EV charging station which uses solar power in conjunction with a tie to the MVDC network to charge the EVs. The operation of the electric vehicle charging station is evaluated with and without connection to the MVDC grid model,

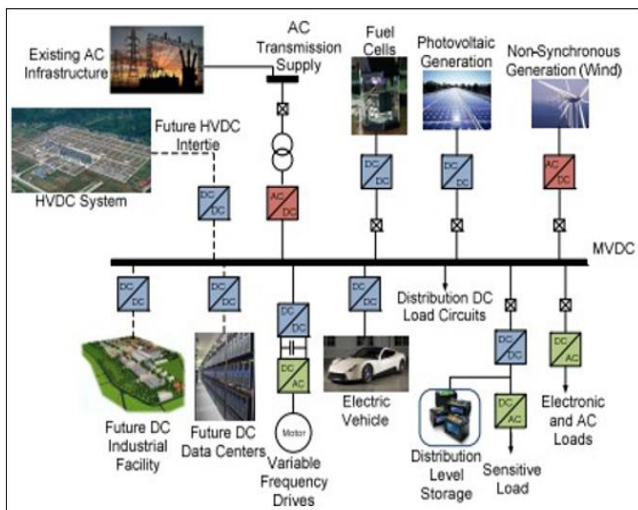

Fig 5 Implementation of Medium Voltage DC Grid for a Network of Stations

Current electric vehicle (EV) charging station installations and simulations are focused on AC chargers which require rectifiers to convert the AC power to DC. The EV charging station is typically tied to an AC distribution supply and has the ability to connect on-site generation in the form of solar photovoltaic panels. Having the EV charging station directly tied into a MVDC architecture is expected to improve system efficiency due to the fact that solar power is generated at DC and the batteries in an EV are a DC load, thus minimizing the number of power conversion stages in the overall system. The EV charging station employs level 3 DC fast chargers, which have the capability of charging within 10 to 15 minutes. During periods of time when the electric vehicles are not using the charging station, the solar panels on the roof may be generating solar power, and the charging station can be used as a generation source which supplies power back to the grid via the bidirectional DC-DC converter. [7]

H. Development of Battery Monitoring System In Smart Microgrid Based on Internet of Things (IoT)

Research has focused on renewable energy sources such as wind, geothermal, hydro, and solar energy, but some of these have disadvantages in producing energy. To overcome these limitations, a system called a smart microgrid has been integrated with a battery system as a backup energy source. The Battery Management System (BMS) needs to be enhanced and the Battery Monitoring System (BMoS) is required to monitor the operational system, performance, and battery life. The Internet of Things (IoT) is the fourth generation of supervisory control and data acquisition (SCADA), a system to monitor and control which communicates through an internet gateway. Cloud system is the best partner for data storage for IoT.

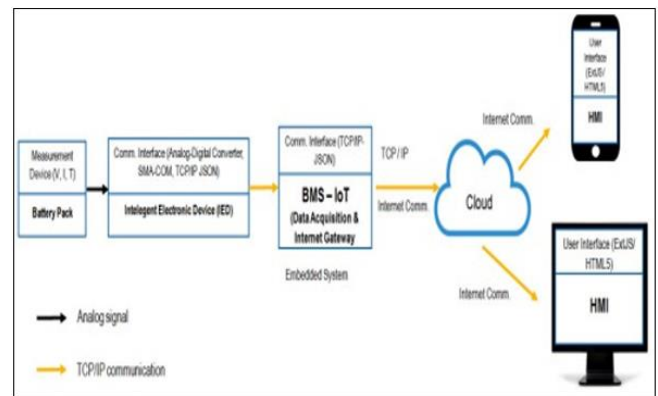

Fig 6 Proposed Blockdiagram of a IoT Battery pack

Cloud system is a third party for database which transfers data over internet gateway. It has advantages such as large data storage, high reliability, low cost, and excellent scalability. IoT has been implemented in various domains, such as transportation and logistics, environment (home, office, and plant), personal and public, biomedical, and energy. Energy domain based on IoT allows users to visualize energy consumption in real time. Smart grid application has been developed for contingency management using smart loads. A battery monitoring system was developed as central module to monitor operational and performance of batteries in smart microgrid system based on IoT. [8]

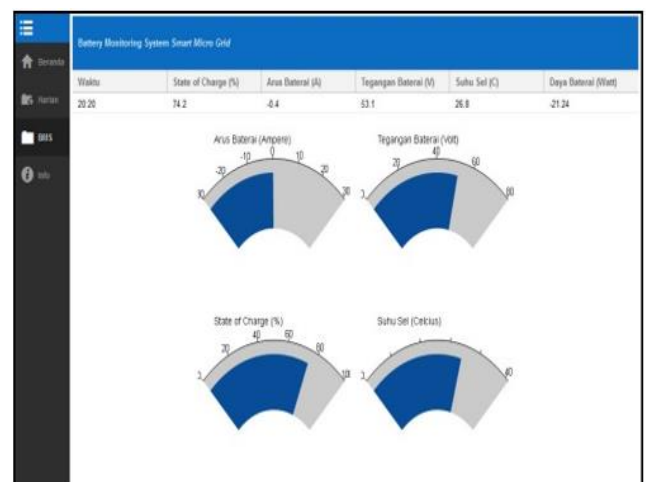

Fig 7 GUI Monitoring of IoT Battery Pack

### III. PROBLEMS WITH EXISTING SYSTEM

- Our goal is to build an automatic electric vehicle charging station which offers both Level 2 (AC) and Level 3 (DC Fast) Charging.
- The unit must supply charge only when vehicle is properly connected and payment status is successful and properly verified.
- The station should also be integrated with an online UPI based Payment gateway should have a transaction verification Method
- The charging should start with both triggers from prior mentioned systems only. this will also allow us to calculate charging time for the user and also number of units of charge consumed which is needed for calculating the bill and generating payment invoice.
- We will also be implementing a J1772 standard connection and Pilot Communication protocol to verify and communicate with the BMS of the car battery, this ensures that a proper vehicle is connected, ready to charge and has requested charge before charging starts.
- We will need to develop a system that can charge a real 18650 NMC Chemistry, 3S5P Battery pack with a 3S BMS and pilot protocol for the implementation to be completed.
- All our Implementations must have SAE Standard Safety checks and measures taken to prevent mishaps with the system. A technician must be notified if major fault is detected.
- For user interface we must make a GUI which will facilitate the user to interact with the station and also enable payments.
- The project should have emergency cut off switches to allow the user to terminate the charging process midway or to completely shut down the system.
- The voltage and current at which the car is being charged should be continuously measured and if there is any fluctuation the supply should be disconnected.

### IV. PROPOSED SOLUTION TO ABOVE PROBLEMS

- We have separate Isolated DC and AC charging connectors, output ports, tracks and relays to ensure that the individual paths do not interfere with each other. and also we are using a boost converter and a switch mode power supply in a combination which allows us to provide DC fast charging.
- Constantly monitor the pilot pin even while charging to ensure that the necessary protocol can be followed on the event that a vehicle is disconnected or not connected properly.
- Verify the status of payment using the razorpay client and record the payment amount and other details in the database along with the pilot pin state, only allow charging if all the necessary conditions are true.
- Read and implement the J1772 SAE standard handbook and implementation guide, choose the components according to the maximum expected output and implement the pilot communication circuit which communicates di-

rectly with the BMS of the car.

- Embed temperature sensors and emergency buttons of the housing of the system and program the system to send a mail if either of those conditions are true to notify the owner and engineer.
- Build a 18650 NMC 2S5P Battery pack with a BMS and check stability of DC supply before connecting. Once connection is done make sure battery is charging within acceptable parameters and all safety systems are working during and after charging with payment and invoice generation.
- Build a web interface for the user to comfortably interact with and understand instructions on how to use the system, have a stop charging button on the housing that stops the charging without any emergency protocol and records the time of stopping charging to grant refunds when needed.
- Implement GFCI checks that ensure no current is leaking in the supply and thus the system is safe to handle, if the GFCI check returns a non zero leak current value shut down the systems and send a maintenance request to the concerned engineer and owner of the system.

### V. IMPLEMENTATION AND METHODOLOGY

The project flow starts when the user arrives at the charging station. The user will be greeted by the welcome screen along with basic details about how to use the system to charge their vehicle. The user will not be able to progress further unless the vehicle is connected. Once the vehicle is connected and verified by the pilot protocol the user can click the proceed button to access the next page. The second page contains a form for the user to fill in order to proceed, here the user will select their charging method (either AC charging or DC charging). Following this page we have our payment client Razorpay UPI gateway, here the user can select their preferred mode of payment and complete the payment process. Once the payment is complete the station verifies the completion of the transaction from the database and if it is successful then it starts the charging process by activating the corresponding relay. The charging time is calculated according to the amount paid by the user.

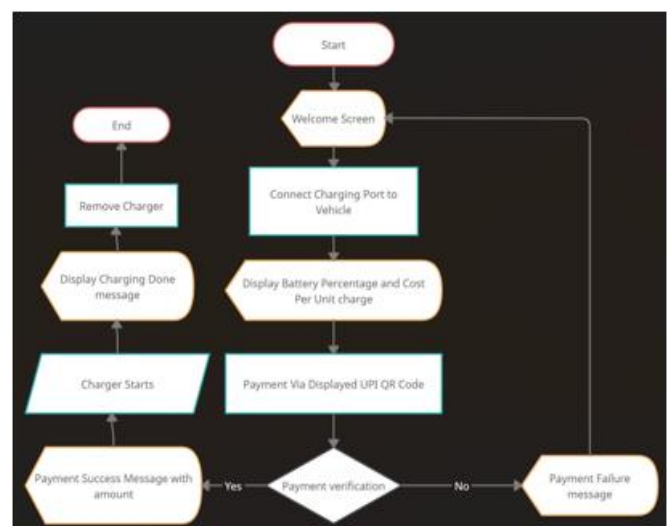

Fig 8 Client Side Flow

If the user wishes to leave early they can press the stop charging button situated on the outer structure of the station as shown in Figure ?? in order to terminate the process early. If the system is having any issue the user can push the kill switch to notify the owner and concerning engineer about the problem. The system will shut down after sending mail notifications to both. If there is no issue with the system the charging will stop once the timer runs out or the vehicle is disconnected.

## VI. MODULE DESCRIPTION

### A. Charging Modules

- AC charging:

The charging station in it's current state can provide 230V supply for charging any 2 wheeler or 4 wheeler electric vehicle. This system module is controlled by the raspberry pi and the 30A AC relay, Shown in Figure 11. This supply gets fed directly into the output on completion of payment procedure and the user selecting AC charging.

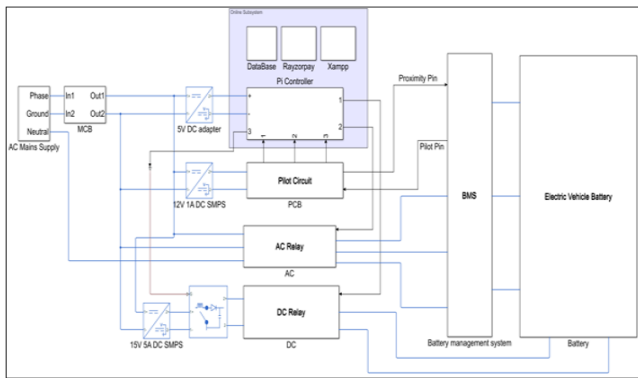

Fig 9 Functional Block Diagram of system

- DC Charging:

The DC Switch mode power supply and boost converter combination, as shown in Figure VI-A, we have implemented can charge our 3S5P 18650 Li-ion cell battery pack from 0% SOC to 100% SOC in Minutes while supplying 12V 7A of current on average. This supply is very fast and can be scaled up to the level of an electric vehicle battery with temperature considerations.



Fig 10 Boost Converter and DC Relay

### B. Vehicle Verification

The process of ensuring that only a genuine electric vehicle is connected at the station outlet is a very important safety task and is performed by the pilot circuit Shown in Figure 11. It communicates and negotiates with the internal BMS of the vehicle to result in 4 possible acceptable states.

- +12V at pilot pin, meaning vehicle is not connected.
- +9V at pilot pin, meaning that Vehicle is connected but not yet ready to charge, at this point diode check is performed for confirmation.
- +6V at pilot pin, this means that the vehicle has requested charge and is now ready for charging.
- +3V at pilot pin, this means that the vehicle is currently charging.

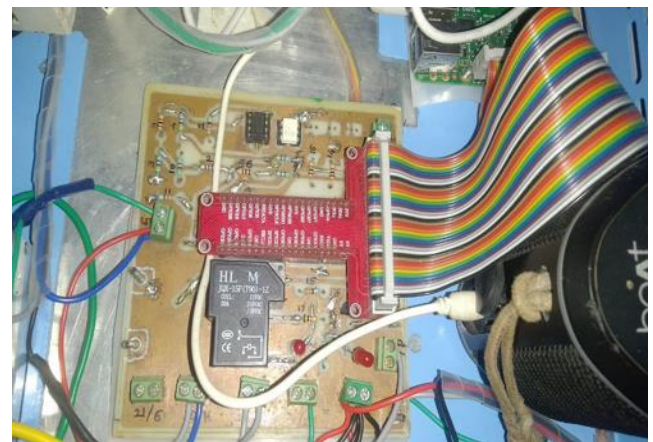

Fig 11 Pilot communication and Vehicle verification circuit

### C. Payment Verification

The payment verification system consist of the server side database and the razorpay UPI client [3]. When the QR code for each transaction is generated the transaction record is stored and sent back by razorpay. this data is entered into the database and referred back to for verification of each transaction. the timer and charging starts once the payment verification is completed along with the charging relays. payment invoice is generated after each session and sent to the user and also stored in the system for future book keeping or dispute management as shown in Figure VII-C.

### D. Security Modules

As our system deals with high power applications safety is a major concern. We have followed the SAE (Society of Automotive Engineering) Standard to avoid any safety hazard while building and operating the system. the system is packed with MCBs at every power inlet. The system houses an emergency kill switch which is to be pressed in case of any malfunction in the system, this button when pressed notifies the owner and maintenance engineer via mail and then completely shuts off. the keys to the project are kept with the owner so that once kill switch is pressed only authorized personal may open the station.

### E. Data Flow Diagrams

User communicate with the home page where basic instructions on how to use the system are mentioned. The back-end will firstly check the vehicle connection status and

will feed it to the database. The home page will fetch the data of vehicle connection status, based on the status it will proceed to next page i.e the payment/credentials page, simultaneously voice commands regarding success will appear. The payment page will take all the required inputs and feed it into the database and once the payment is successful the system will start the charging process and the UI will display the Thank you page.

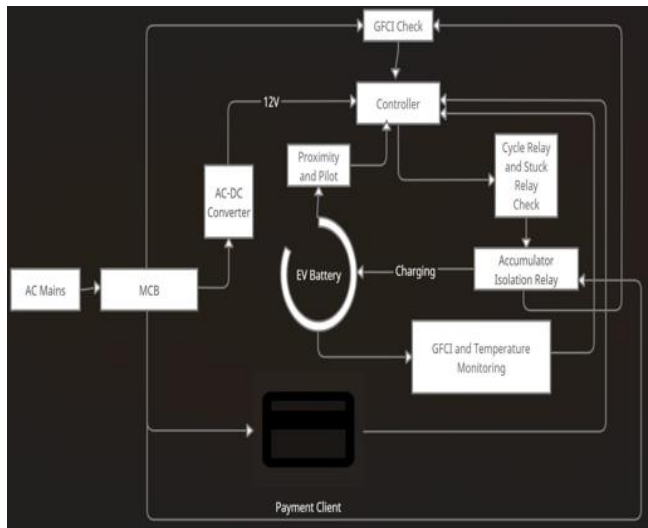

Fig 12 Diagram showing the flow of data in the system

Once the charging starts the system will continuously check the conditions of reset button and emergency button. If the reset button is pressed the thank you page will generate a invoice which will be sent to the user as well as to go back to the home page. If the emergency button is pressed then the whole system will shut down with a message to the technician will be sent.

F. E-R Diagram

➤ Shown in Figure VI-F

The entity-relation diagram shows the relationship between the tables of the database.

G. Database Design

The database is implemented on MySQL on Xampp Server where the name of database is Charging point. In the database five tables is created.

- The vehicle connect stores the status of vehicle connection which acts as trigger for the click status table with relation of one to one.
- The click status will the stores the status of home page button which will be trigger for the transaction table in relation of one to many.
- The machine table will store the status of the system in relation with one to many .
- The transaction table will store all details of credentials like payment status, payment id, vehicle number and email id
- The reset will store the status reset button.

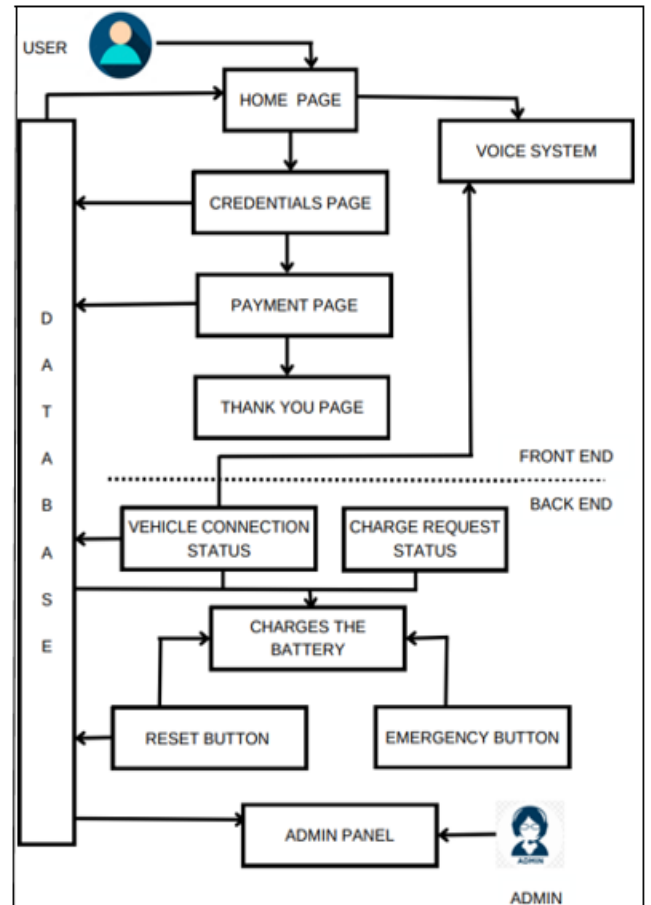

Fig 13 Software Dataflow for backend

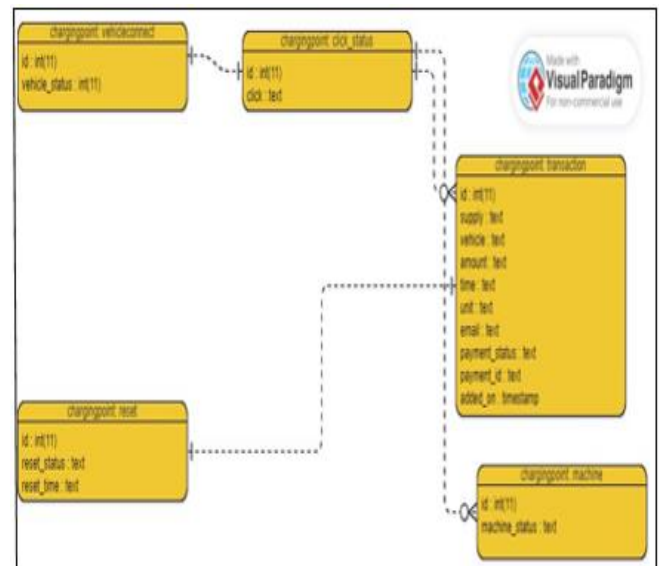

Fig 14 E-R diagram for our database

Table 1 Pilot Communication

State	Pilot High	Pilot Low	EV Resistance	Communication
A	+12V	-12V	N/A	Not Connected
B	+9V	-12V	2.74 kOhm	EV Connected
C	+6V	-12V	882 Ohm	EV Connected
D	+3V	-12V	246 Ohm	Charge Requested



H. Pilot Algorithm

The Pilot communication is a standard defined by SAE and OpenEVSE are shown in the table I. This communication

Fig 15 MySQL Database

Is carried out at 1 MHz frequency using PWM. this is used in tandem with diode checks and other safety measures to implement vehicle verification facilitating the communication process.

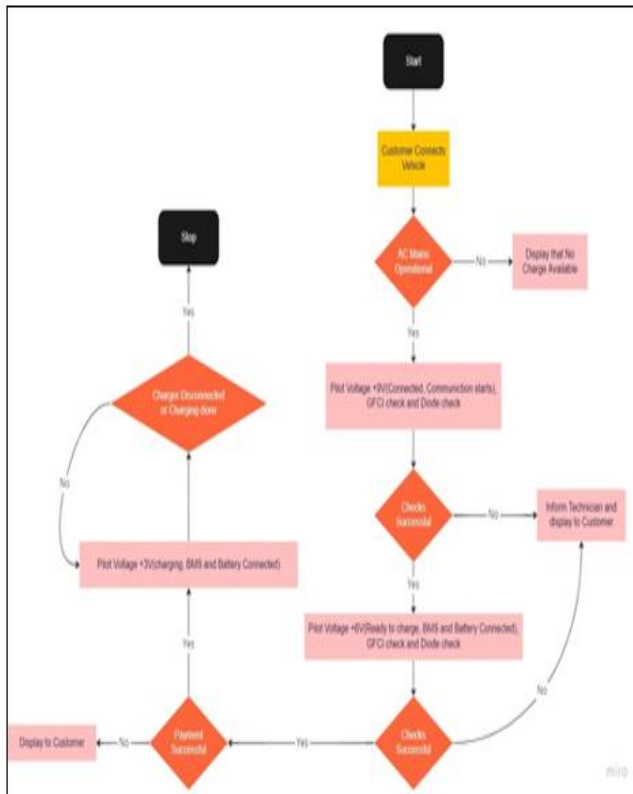

Fig 16 Pilot Algorithm

VII. USER INTERFACE

The user interface of our system is on a 7 inch LCD display compatible with Raspberry Pi.

A. Homepage



Fig 17 Home Page

The home page mentions a little summary about our system where the page checks if vehicle is connected. If vehicle is not connected a pop-up message appears.

B. Admin Page

Sr.No	Email ID	Vehicle	Supply	Unit	Time	Amount	Payment Status	Payment ID	Date and Time
1	abhishkathan23@gmail.com	BV 10 Alternating CC 1664	Current	26.87	6.67	₹ 200	pending	-	2023-04-21 11:46:14
2	croce.9067.ecsi@gmail.com	BV 10 Alternating BC 1234	Current	6.22	1.54	₹ 100	complete	pay_L2PUtL0I0HT0a8	2023-04-03 23:32:03
3	croce.9067.ecsi@gmail.com	BV 10 Alternating AC 1234	Current	6.22	1.54	₹ 100	complete	pay_L2MeymzF7JLhC	2023-04-03 09:30:28
4	mohitathani1559@outlook.com	BV 10 Alternating CB 1234	Current	6.22	1.54	₹ 100	complete	pay_L2ZNB8J4pP9t4	2023-04-02 09:24:36
5	abhishkathan23@gmail.com	BV 10 Alternating CA 1234	Current	6.22	1.54	₹ 100	complete	pay_L2ZLXic0T3ng5Dr	2023-04-02 09:22:51
6	croce.9067.ecsi@gmail.com	BV 10 Direct CC 1234	Current	6.22	4.98	₹ 100	complete	pay_L2YvYt7vNY6xK	2023-04-02 08:59:21
7	croce.9067.ecsi@gmail.com	BV 10 Alternating CC 1234	Current	1.04	0.26	₹ 75	complete	pay_LQ7pP8c2V6l9xH	2023-03-11 07:46:13
8	croce.9067.ecsi@gmail.com	BV 10 Direct CC	Current	6.22	4.98	₹ 100	complete	pay_LQ7Xic48F6hNYI	2023-03-11

Fig 18 Admin page

The admin page displays all the records and transactions related to the system.

The admin/owner of the charging stations will have this interface to manage all the stations on the same grid along with transactions.

C. Payment page and Gateway

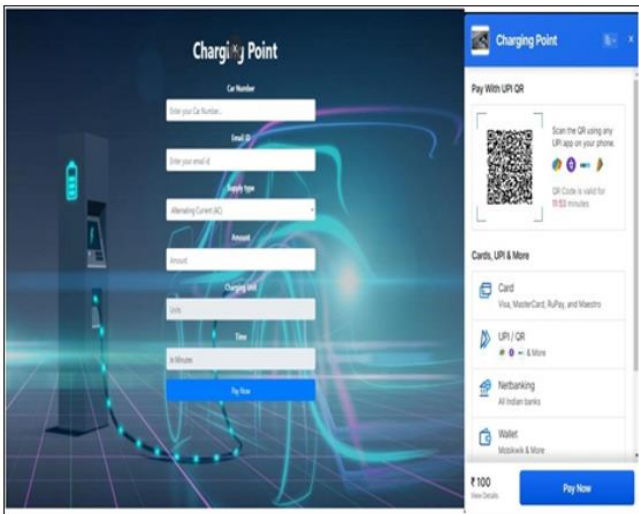

Fig 19 Credential Page and Payment Gateway

The credentials page store all the required details of the user in the database. The payment gateway is basic gateway where the amount is reflected from to the user to owner.

D. Thank you page

The last page which is thank you page includes a count-down timer and generates invoice when the reset button is pressed or the charging is completed.

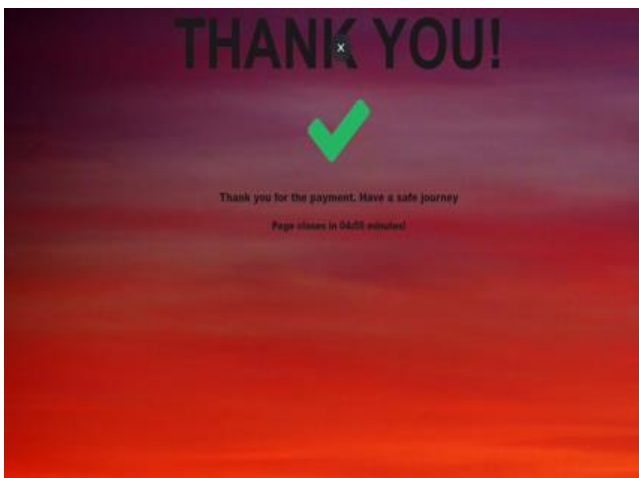

Fig 20 Thank you / Counter

The last page which is thank you page includes a count-down timer and generates invoice when the reset button is pressed or the charging is completed.

VIII. WORKING

A. Setup and Deployment

The implementation of an automatic electric vehicle (EV) charging station with a razorpay UPI payment client and support for both AC and DC fast charging requires a well-planned methodology to ensure successful deployment and operation. The first step in this process is to ensure that the station has a reliable power supply, which in this case requires a 230V AC mains supply.

Once the power supply is established, the charging process can begin. The station is designed to only initiate the charging process when a car is plugged in. The system will then check the status of the car via the pilot and show the status on the status LEDs. This helps to ensure that the car is properly connected and ready to receive a charge.

When the battery management system (BMS) of the cars sends a charge request, the payment process will start. The user will need to fill out a form and select the type of charging (AC/DC) required. Once the form is completed, the payment gateway will commence, and the user will be able to choose the method of payment. This could include options such as debit/credit card or UPI payments via razorpay.

The transaction will be updated in the database along with the form data, which will help to keep track of the charging history and payment details. If the payment is successful, an invoice will be generated and emailed to the user. This invoice will contain details such as the amount paid, the charging duration, and any other relevant information.



Fig 21 Internal arrangement of Modules

Once the payment process is completed, the charging process will begin. The time of charging will be displayed on the screen, allowing the user to keep track of the progress. The charging process will stop once the timer is completed or the vehicle is disconnected. This ensures that the car is not overcharged, which could damage the battery.

To ensure that the system is reliable and operates as intended, rigorous testing will be required. This will involve testing all possible failure cases that could occur with the charging station. This could include situations such as power outages, network failures, and issues with the payment gateway. By testing these scenarios, the system can be improved and made more resilient to potential issues.

In terms of the actual implementation of the charging station, several key components will need to be integrated. These include the charging hardware, the payment gateway, the database, and the user interface. The charging hardware will need to be compatible with the J1772 SAE charging standard to ensure that it can be used with a wide range of EVs.

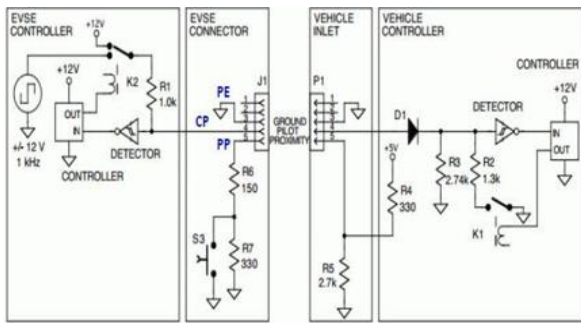

Fig 22 J1772 Standard EV Charging Connections

The payment gateway will need to be integrated with the razorpay UPI client to allow for seamless payments. The database will need to be designed to store and retrieve the charging and payment data, allowing for easy tracking and reporting. Finally, the user interface will need to be designed to allow users to easily initiate and monitor the charging process.

To ensure that the charging station is safe and secure, several measures will need to be put in place. This could include the installation of an emergency kill switch and a stop charging button. These features will help to ensure that the charging process can be stopped quickly in the event of an emergency.

In addition to these safety features, the charging station will also need to comply with all relevant regulations and standards. This could include requirements related to electrical safety, data privacy, and payment security. Compliance with these regulations will help to ensure that the charging station is safe and reliable for use by EV owners.

For the implementation of the DC Fast charging we built a 18650 NMC chemistry 3S5P Battery Pack of a total charge holding capacity 18000mAh with a 3S BMS for testing, shown in Figure VIII-A. this battery would be completely charged by our system in less than 2 mins. at a C-rate of 0.75C.



Fig 23 Battery Pack for testing

**IX. CONCLUSION**

In essence, the implementation of an automatic EV charging station with a razorpay UPI payment client and support for both AC and DC fast charging requires a comprehensive methodology that takes into account all aspects of the design, implementation, and operation of the station. By following a well-planned methodology, it is possible to ensure that the station is reliable, safe, and secure, and provides an excellent alternative to simplistic electric vehicle charging stations.

**ACKNOWLEDGMENT**

We have great pleasure in presenting the paper on "Auto- matic Electric Vehicle Charging Station Prototype". I take this opportunity to express my sincere thanks towards the guide Prof. Bincy Joseph, C.R.C.E, Bandra (W), Mumbai, for pro- viding the technical guidelines, and the suggestions regarding the line of this work. We enjoyed discussing the work progress with her during our visits to department.

We thank Dr. Sapna Prabhu, Head of Electronics and Computer Science Dept., Principal and the management of C.R.C.E., Mumbai for encouragement and providing necessary infrastructure for pursuing the project.

We also thank all non-teaching staff for their valuable support, to complete our project.

**REFERENCES**

- [1]. K. N. N. A. Jadhav Akshada, Ghorpade Ganesh, "Smart charging of Electric Vehicles", 2020.
- [2]. W. C. Z. Shaohua Cui, Hui Zhao, "Locating multiple size and multiple type of Charging Station for Battery Electricity Vehicles," 2018.
- [3]. P. N. A. V. Radhika Basavaraj Kakade, "Unified payment interface (upi) - a way towards cashless economy," 2017.
- [4]. L. F. G. N. P. Pieter C. Bons, Aymeric Buatois and R. van den Hoed, "Impact of Smart Charging for consumers in a Real World Pilot," 2020.
- [5]. G. A. Z. A. Kuperman, U. Levy and A.Savernin, "Modeling and control of the pfc stage for a 50kw EV fast battery charger," 2011.
- [6]. S. C. P. C. Visal Raveendran, Divya R. and M. G. Nair, "Smart level 2 dc electric vehicle charging station with improved grid stability and battery backup," 2017.
- [7]. R. J. K. a. G. F. R. Adam R. Sparacino, Brandon M. Grainger, "Design and simulation of a dc electric vehicle charging station connected to a mvdc infrastructure," 2012.
- [8]. B. M. S. D. K. E. L. B. Y. Koko Friansa, Irsyad Nashirul Haq, "Development of battery monitoring system in smart microgrid based on internet of things (iot)," 2017.