

Energy, Exergy and Simulation Analysis of Steam Driven High Pressure Pumps of Cogeneration Plants

Haruna Abubakar
Mechanical Engineering
Department,
Kaduna Polytechnic,
Kaduna, Nigeria

Habou Dandakouta
Mechanical/Production Engineering
Department, Abubakar Tafawa
Balewa University, Bauchi,
Nigeria

Kaushal Singh
Department of Computer Science
and Information Technology, P P
Savani University, Kosamba, Surat,
India

Abstract:- High-pressure pumps are centrifugal pumps that increase the feed water pressure before it enters the boiler. The performance of the Kaduna Refining and Petrochemicals Company Power Plant has been impacted by their decline from their design output. Adopting strategies that will boost pump performance and enhance the plant's functionality is essential. A mathematical model for the KRPC HP Pump was established, and a simulation program for energetic and exergetic analysis of the pump was created. The program was validated in free and open-source literature with a benchmark percentage error of 10% or less. It is based on Python programming code. The program used in the analysis had a maximum percentage error of 1.42%, demonstrating the validity of the simulation program. The results showed that the energy efficiencies of HP Pumps 1 and 2—which were each 82.03% at design conditions—were lowered to 67.14% and 61.33% at operating conditions, and the exergy efficiencies—which were each 25.6% at design conditions—were reduced to 21.2% and 19.36%. Exergy destruction increased from 5.0410 MW each at design condition to 5.0649 MW and 5.1827 MW at operational condition, and energy losses increased from 1.1368 MW each at design condition to 1.9573 MW and 2.3033 MW at operating condition. An analysis has found that HP pumps are more energy and exergy efficient under design settings than under operating conditions. Leaks or insufficient insulation are the causes of these losses. It is recommended that the power plant be run at design conditions, in the absence of this, the control system of the plant should be in good condition.

Keywords:- Energy; Exergy; Efficiency, Simulation;

I. INTRODUCTION

Cogeneration plants are highly efficient systems that generate electricity and useful thermal energy from a single fuel source. High-pressure pumps, which include reciprocating pumps, centrifugal pumps, and diaphragm pumps, are pumps that produce high-pressure outputs in order to transfer fluids at high pressures. [1]; [2]. It is essential that people today are aware of how to regulate their energy, so it is important to conduct study like this. Energy and exergy analysis are based on first and second law of thermodynamics. Deterioration in performances of HP Pumps also affects the thermal performance of a plant as a whole [3]. Thermal performance of a typical power plant is primarily due to efficient pressure boost through the HP Pumps. Therefore, the effectiveness of these pumps has a

substantial influence on the whole performance of the plant [3]; [4].

To the delight of her clients, Kaduna Refining and Petro-chemical Company (KRPC) refines crude oil into premium petroleum products and produces petrochemical and packaging goods. [5]. The power plant and utilities (PPU) department, comprises of utilities and power plant sections. The HP Pumps as shown in figure 1 are faced with the problem of deterioration from its design output, which lead to less performance of the power plant. Through the identification of losses, destructions, and efficiencies, the simulation program hopes to address these issues and disclose the extent of losses that occur in HP Pumps. It will also serve as a guide for the company's management regarding the maintenance schedule for the plant. Energy and exergy analysis is a process that not only assesses performance but also optimizes and recommends changes to be made to the power plant to increase performance. [6]; [7]. Python is a strong and well-liked programming language that is extensively utilized in many industries. It is known for being straightforward, readable, and adaptable, making it an excellent option for novice and seasoned programmers. Python's ability to be directly executed rather than being translated into machine code as an interpreted language is one of its key characteristics [8].



Fig. 1: KRPC HP Pumps

The analysis of energy and exergy in thermal power plants and its constituent parts has been the subject of numerous studies. A physical model was transformed into a python-based simulation program and validated based on literature data [9]. The results revealed high qualitative and quantitative conformity with literature data. It was revealed that boiler has the maximum exergy destruction of 490.76 MW when the performance of a 250 MW thermal power

plant based on exergy consideration using MATLAB calculation tool was analyzed [10]. The Authors assessed a condenser at different operating scenarios in a coal fired power plant and found that a degree Celsius change in cooling water temperature led to 0.59 kPa deviation of the condenser pressure, 0.36% heat rate deviation and 33 MW unit generation in the cycle of the plant [11].

In a similar vein, it was revealed that the combustion chamber has the largest exergy destruction of 73% and the plant's energy and exergy efficiency decrease with increase in the ambient temperature when they carried out thermodynamic analysis of a plant in Jordan [12]. A 200 MW Shahid Montazeri power plant of Isfahan using Engineering Equation Solver software was investigated [13]. It was found that 69.8% of the total energy lost occurred in the condenser and 85.66% of the total exergy destroyed was found in the boiler. The effect of using different number of feed water heaters on the cycle performance of a 200 MW Shahid Montazeri steam cycle power plant was also investigated [14]. The performance study was simulated on a validated model of the plant and the result revealed that the combustion chamber of the boiler has the maximum exergy destruction while the energy and exergy efficiencies of the plant were 37.5% and 41.7% respectively. The validated results were found satisfactorily when the simulation modeling of a 250 MW capacity coal-based power plant at different load conditions using the MATLAB was studied [15].

II. KRPC POWER PLANT

The boiler feed water (BFW), which originates from the demineralized water unit at 45°C, 9 bar of pressure, and 1 ppm of dissolved oxygen, is sent to the deaerators, where the BFW's pressure, temperature, and dissolved oxygen content change to 2.5 bar, 125°C, and 0.007 ppm, respectively, as shown in fig. 2. Following the deaerators, high pressure (HP) pumps raise the boiler feed water (BFW) pressure to 60.5 bar while maintaining the water's

temperature and dissolved oxygen content. In order to further boost the temperature to 140°C, the boiler feed water (BFW) is subsequently supplied to the boilers via HP Heaters. Boiler feed water (BFW) enters the boilers through their corresponding economizers at 140°C and 60.5bar at 270t/hr. Following the appropriate economizers, the boiler feed water is saturated and arrives at the steam drum at 185°C and 52.4bar pressure. The internals of the drum separate the steam from the saturated water (horizontal separators and chevron driers). After passing through the primary and secondary superheaters, the dry steam is subsequently further heated before entering the high-pressure steam headers (SH). Between the primary and secondary superheaters, there is also a superheater steam temperature control device (spray type attemperator) placed, which maintains the steam temperature at the superheater outlet at the desired 412°C and 42.5bar pressure.

This superheated steam is used to drive the prime mover (turbines) of the turbo generators to generate power and also drive other turbine pumps for pumping boiler feed water at the required pressure. After utilizing the superheated steam (SH) in the HP pumps and in the turbines, the medium pressure steam (SM) extracted from the turbines and from the HP pumps were channeled to the common header of medium pressure steam (SM). The medium pressure steam (SM) at temperature of 300°C and pressure of 16.4bar is used to drive the LP pumps and for heat exchange with boiler feed water (BFW) in the heaters. The low-pressure steam (SL) at temperature of 175°C and pressure of 1.44bar from the LP pumps is sent to the Deaerators for heat exchange with the boiler feed water, while the condensate from the heaters is also sent to the Deaerators to make-up level of the boiler feed water (BFW). The medium pressure steam (SM) from the turbines which were condensed under vacuum at a pressure of 18.2bar are sent to the condensate tank (CT) via the condensate pumps (CP) and it flows back to the Demineralized unit and the process is repeated [16]. The process is depicted in fig. 2.

Nomenclature

BFW	Boiler feed water
CDT	Condensate
CW	Cooling water
CA	Combustion air
ESM	Extracted medium pressure steam
CSM	Condensed medium pressure steam
De	Deaerator
HPP	High pressure pump
LPP	Low pressure pump
He	Heater
Bo	Boiler
STG	Steam turbine generator
TC	Turbine condenser
HW	Hot well
CP	Condensate pump
CT	Condensate tank
DU	Demineralized unit
CU	Combustion unit
HEU	Heat exchange unit
KRPC	Kaduna refining and petro-chemical company
HHV	high heating value of fuel (kJ/kg)
LHV	low heating value of fuel (kJ/kg)
AAF	actual air-fuel ratio of fuel (kg of air/kg of fuel)
\dot{E}	Energy flow rate (kJ/s)
\dot{E}_x	Exergy flow rate (kJ/s)
\dot{E}_{xD}	Exergy destruction (kJ/s)
C_p	Specific heat capacity (kJ/kgK)
\dot{M}	Mass flow rate (Kg/s)
\dot{Q}	Rate of heat transfer to the system (kJ/s)

\dot{Q}_L	Rate of heat loss (kJ/s)
\dot{W}	Rate of work done by the system (kJ/s)
\dot{P}_W	Power produce by the system (kJ/s)
h	specific enthalpy (J/Kg)
s	specific entropy (J/Kg K)
P_o	Atmospheric pressure (bar)
T_o	Atmospheric Temperature (°C)

Greek letters

η_I	Energy efficiency (%)
η_{II}	Exergy efficiency (%)
ϵ	specific exergy (kJ/Kg)

Sub_ and superscripts

SH	High pressure steam
SM	Medium pressure steam
SL	Low pressure steam
FW	Feed water
FO	Fuel oil
F	Fuel
FG	Flue gas
A	Air
S	Steam
<i>comb</i>	Combustion
HP	Hot products
0	reference state

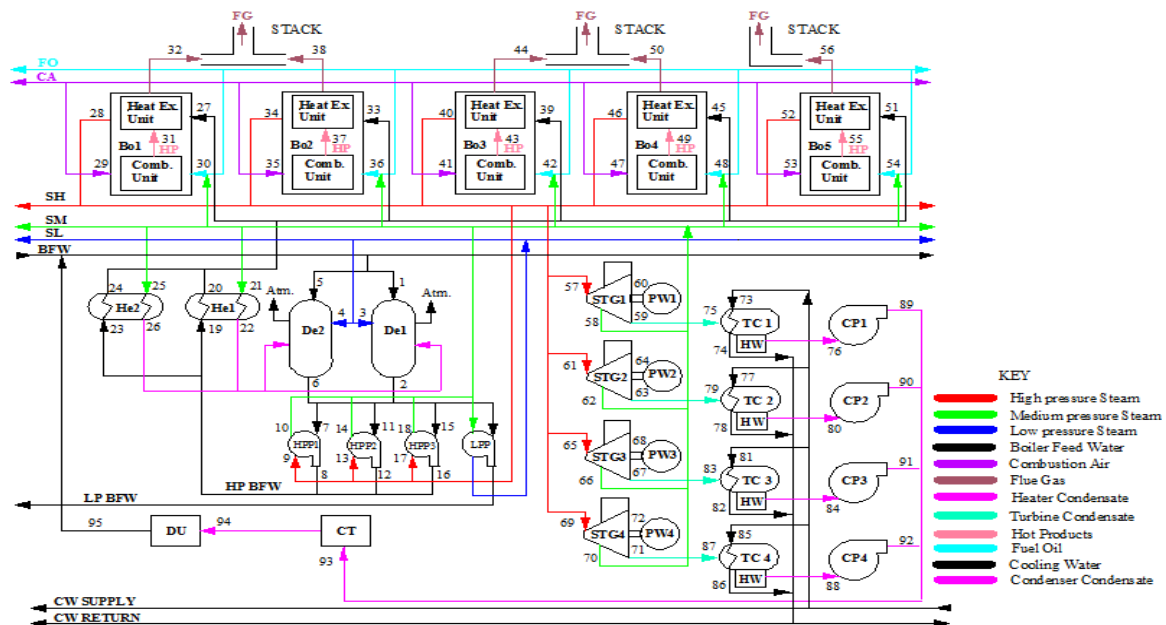

Fig. 2: Schematic flow diagram of KRPC steam power plant

III. METHODOLOGY

The schematic flow diagram was produced after researching the plant's operational process. Additionally, utilizing energy and exergy analysis based on component-wise technique, the general mathematical model of a typical component was built.

A. Mathematical Model of KRPC HP Pumps

Thermodynamic theories, a generic mathematical model based on component-by-component modelling, and a schematic flow diagram of the power plant were all used to build the mathematical model of the HP Pumps. Only HP Pumps 1 and 2 were examined during this study project, as indicated in figs. 3 and 4.

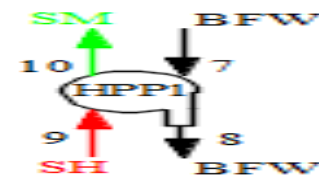

Fig. 3: Schematic flow diagram of HP Pump 1

Energy efficiency (%):

$$\eta_{I(HPP1)} = \frac{\dot{M}_8 h_8 - \dot{M}_7 h_7}{\dot{M}_9 h_9 - \dot{M}_{10} h_{10}} \times 100\% \quad (1)$$

Exergy efficiency (%):

$$\eta_{II(HPP1)} = \frac{\dot{M}_8 \epsilon_8 - \dot{M}_7 \epsilon_7}{\dot{M}_9 \epsilon_9 - \dot{M}_{10} \epsilon_{10}} \times 100\% \quad (2)$$

Energy loss (MW):

$$\dot{Q}_{L(HPP1)} = (\dot{M}_9 h_9 + \dot{M}_7 h_7) - (\dot{M}_8 h_8 + \dot{M}_{10} h_{10}) \tag{3}$$

Exergy Destruction (MW):

$$\dot{E}_{XD(HPP1)} = (\dot{M}_9 \epsilon_9 + \dot{M}_7 \epsilon_7) - (\dot{M}_8 \epsilon_8 + \dot{M}_{10} \epsilon_{10}) \tag{4}$$

Where:

$$\epsilon_7 = h_7 - T_0 s_7 \tag{5}$$

$$\epsilon_8 = h_8 - T_0 s_8 \tag{6}$$

$$\epsilon_9 = h_9 - T_0 s_9 \tag{7}$$

$$\epsilon_{10} = h_{10} - T_0 s_{10} \tag{8}$$

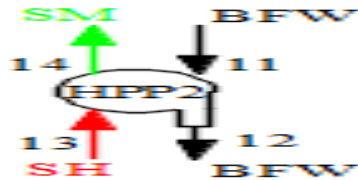

Fig. 4: Schematic flow diagram of Pump 2

Energy efficiency (%):

$$\eta_{II(HPP2)} = \frac{\dot{M}_{12} h_{12} - \dot{M}_{11} h_{11}}{\dot{M}_{13} h_{13} - \dot{M}_{14} h_{14}} \times 100\% \tag{9}$$

Exergy efficiency (%):

$$\eta_{III(HPP2)} = \frac{\dot{M}_{12} \epsilon_{12} - \dot{M}_{11} \epsilon_{11}}{\dot{M}_{13} \epsilon_{13} - \dot{M}_{14} \epsilon_{14}} \times 100\% \tag{10}$$

Energy loss (MW):

$$\dot{Q}_{L(HPP2)} = (\dot{M}_{13} h_{13} + \dot{M}_{11} h_{11}) - (\dot{M}_{12} h_{12} + \dot{M}_{14} h_{14}) \tag{11}$$

Exergy Destruction (MW):

$$\dot{E}_{XD(HPP2)} = (\dot{M}_{13} \epsilon_{13} + \dot{M}_{11} \epsilon_{11}) - (\dot{M}_{12} \epsilon_{12} + \dot{M}_{14} \epsilon_{14}) \tag{12}$$

Where:

$$\epsilon_{11} = h_{11} - T_0 s_{11} \tag{13}$$

$$\epsilon_{12} = h_{12} - T_0 s_{12} \tag{14}$$

$$\epsilon_{13} = h_{13} - T_0 s_{13} \tag{15}$$

$$\epsilon_{14} = h_{14} - T_0 s_{14} \tag{16}$$

B. Simulation Program for KRPC HP Pumps

In this paper we used different functionalities python within the three main components of a pump i.e., Mass flowrate, Temperature and Pressure. A conditional statement is a type of control flow statement that allows you to execute a certain block of code only if a certain condition is met.

if condition: # Code to execute if condition is True

So, combining all these functionalities of python, the simulation program was built and connected with User interfaces which were built by the frameworks of Python called Django.

Django is a free and open-source web framework written in Python. It is used by many high-profile websites, including Instagram, Pinterest, and The Washington Times. Django is known for its emphasis on security and performance with features such as cross-site request forgery protection. The flowchart of Algorithm and interfaces are shown in fig. 5 to 7.

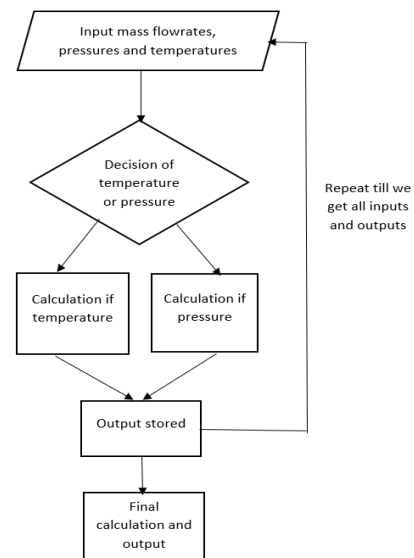

Fig. 5: Flowchart of Algorithm

TOC 32		Operating	
Description	Inputs		
	M(Kg)	P(bar)	T(°C)
Boiling Feed Water entering HP pump	68	pressure Enter pressure for BFW entering HP pump 2.4	
Boiling Feed Water leaving HP pump	68	pressure Enter pressure for BFW leaving HP pump 5.8	
High Pressure Stream entering HP pump	24	48	409
Medium Pressure Stream leaving HP pump	24	16.5	274
Submit Query			
compare			

Fig. 6: HP Pump input interphase

TOC: 32.0			TOK : 305.0				Name : Operating			
DESCRIPTION	M(Kg)	P(bar)	Pkpa	T(°C)	T(k)	H(kJ/Kg)	S(kJ/KgK)	e(kJ/Kg)	E(kJ/(MJ/s))	EX(kJ/(MJ/s))
BFW entering HP pump	68.0	2.4	240.0	None	None	632.25	1.8569	65.8955	42.993	4.4809
BFW leaving HP pump	68.0	5.8	580.0	None	None	691.07	1.984	85.95	46.9928	5.84
SH entering HP pump	24.0	48.0	4800.0	409.0	682.0	3221.846	6.6963	1179.4745	77.3243	28.3074
SM leaving HP pump	24.0	16.5	1650.0	274.0	547.0	2973.634	6.7606	911.651	71.3672	21.8796
Main Output										
ENERGY EFFICIENCY OF HP PUMP						67.1434				
ENERGY LOSS OF HP PUMP						1.9573				
EXERGY EFFICIENCY OF HP PUMP						21.1441				
EXERGY DESTRUCTION OF HP PUMP						5.0687				

Fig. 7: HP Pump output interphase

C. Validation of Simulation Program of KRPC HP Pumps

If the outputs of the compared plants show only slight changes, which could be brought on by different assumptions and default settings, the simulation program is considered successful [17] as shown in table I, II and III.

Component	Substance	h (kJ/kg) Literature	h (kJ/kg) Simulation	% Error
HP Pump	SH in	3376.17	3376.207	0
	SM out	2931.38	2931.39	0
	FW in	482.73	482.7262	0
	FW out	495.80	495.802	0

Table 1: ENTHALPY PERCENTAGE ERROR

Component	Substance	s (kJ/kgK) Literature	s (kJ/kgK) Simulation	% Error
HP Pump	SH in	6.605	6.605	0
	SM out	7.651	7.6618	0.14
	FW in	1.473	1.4732	0.01
	FW out	1.474	1.474	0

Table 2: ENTROPY PERCENTAGE ERROR

Component	Performance Analysis	Literature	Simulation	% Error
HP Pump	η_I (%)	58.3	58.25	0.08
	\dot{Q}_L (MW)	0.701	0.7019	0.13
	η_{III} (%)	33.86	33.38	1.42
	\dot{E}_{XD} (MW)	1.903	1.9186	0.82

Table 3: Analysis Percentage Error

With a benchmark percentage error of 10%, the simulation outputs of the created computer program for HP Pumps were compared to those of the matching HP Pump of a power plant (India) in free and open-source literature [18]. The validated result showed a maximum error of 1.42%, so attesting to the reliability of the simulation program.

D. Implementation of the Simulation Program

The energy and exergy flow rates at the inlet and exit sites of each HP Pumps were estimated and stated as the input data were gathered, processed, and combined. Then, under design and operating conditions, the energy and exergy efficiencies, energy losses, and exergy destructions for the HP Pumps are estimated independently. The input data and the compared analysis outputs of the HP Pumps at design and operating condition are shown in table IV and V.

Component	Substance	M (kg/s)	P (bar)	T (°C)	h (kJ/kg)	s (kJ/kgK)	ε (kJ/kg)	E (MW)	Ex(MW)
HP Pump	Design Condition								
	FW in	75	2.5	-	633.98	1.8606	60.9152	47.5485	4.5686
	FW out	75	6.5	-	703.18	2.0102	84.0384	52.7385	6.3029
	SH in	25	48	412	3229.03	6.7066	1163.4038	80.7257	29.0851
	SM out	25	16.5	275	2975.96	6.7648	892.39525	74.3989	22.3099
HP Pump 1	Operating Condition								
	FW in	68	2.4	-	632.25	1.8569	65.9076	42.993	4.4817
	FW out	68	5.8	-	691.07	1.9840	85.9439	46.9928	5.8442
	SH in	24	48	409	3221.85	6.6963	1179.4672	77.3243	28.3072
	SM out	24	16.5	274	2973.63	6.7606	911.6611	71.3672	21.8799
HP Pump 2	Operating Condition								
	FW in	66	2.4	-	632.25	1.8569	65.9077	41.7285	4.3499
	FW out	66	5.6	-	687.61	1.9765	84.7653	45.3823	5.5945
	SH in	24	48	409	3221.85	6.6963	1179.4672	77.3243	28.3072
	SM out	24	16.5	274	2973.63	6.7606	911.6611	71.3672	21.8799

Table 4: Input and corresponding data at design and operating condition

IV. RESULTS AND DISCUSSION

The simulation program's HP Pump outputs were compared to the benchmark in the literature, and the modest percentage errors that were found are shown graphically. Similar comparisons were done between the HP Pumps' outputs at design and operating condition, and the few variations that were found are also shown graphically.

A. Validation Analysis of HP Pump Substances

The range of percentage error variation is 0.00% – 1.42%. The maximum percentage error of 1.42% which is less than 10% benchmark was found in exergy efficiency of the HP Pump as shown in figure 13, 14 and 15.

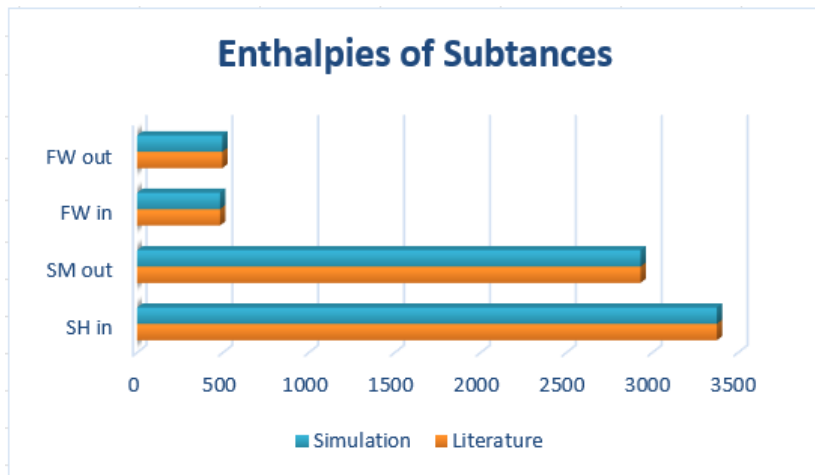

Fig. 8: Enthalpies of HP Pump substances at literature and simulation

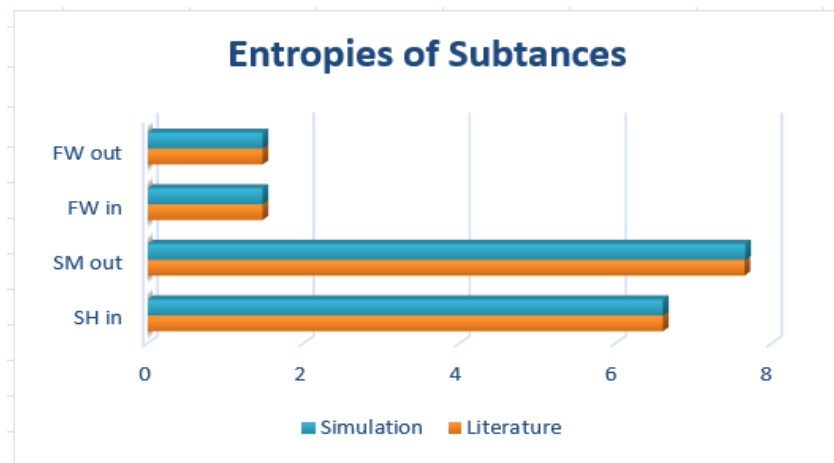

Fig. 9: Entropies of HP Pump substances at literature and simulation

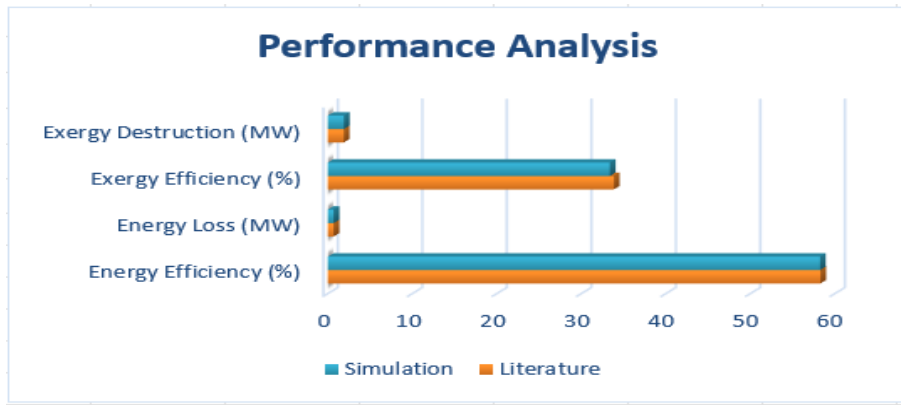

Fig. 10: HP Pump performance analysis at literature and simulation

B. Performance Analysis of HP Pump 1

The power plant's HP Pump 1 under design and operating conditions has undergone a performance analysis. The performance indices graph is displayed in Fig. 16. The graph shows that energy and exergy efficiency, which were respectively 82.03% and 25.6% at design condition, are

reduced to 67.14% and 21.2% at operating condition, while energy loss and exergy destruction, which were respectively 1.1368MW and 5.0410MW at design condition, are increased to 1.9573MW and 5.0649MW operating condition.

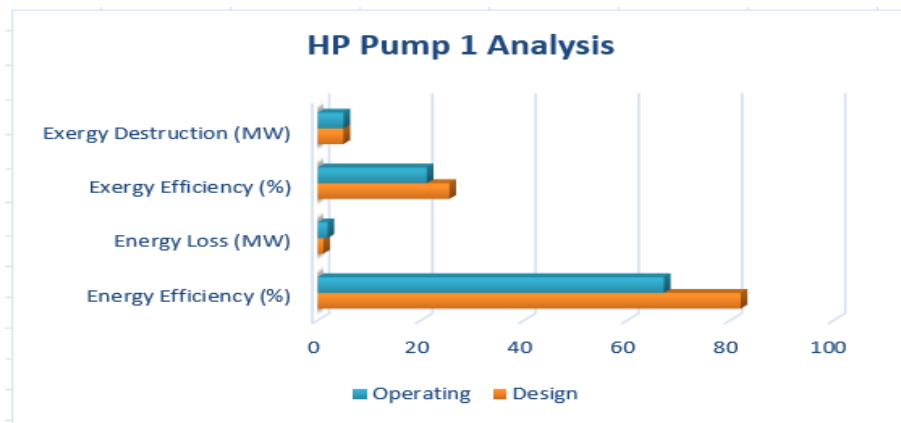

Fig. 11: Performance indices of HP Pump 1 at design and operating condition

C. Performance Analysis of HP Pump 2

The power plant's HP Pump 2 has had its performance evaluated under both design and operational conditions. The graph for the performance indices is displayed in Figure 17. The graph shows that the energy and exergy efficiency, which were 82.03% and 25.6% at design condition, are now

61.33% and 19.36%, respectively, while the energy loss and exergy destruction, which were 1.1368MW and 5.0410MW at design condition, are now 2.3033MW and 5.1827MW, respectively.

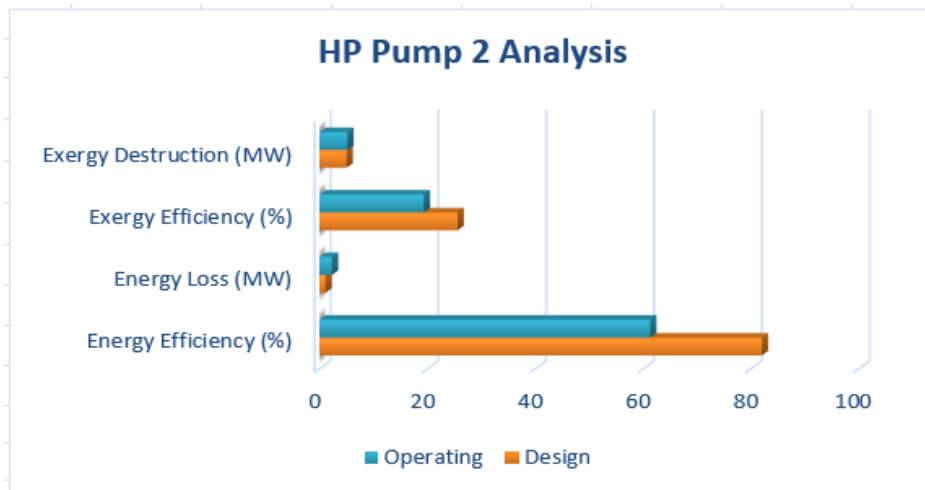

Fig. 12: Performance indices of HP Pump 2 at design and operating condition

V. CONCLUSION

The usage of Python programming languages in creating simulation program and creating simulation interphases is encouraged by this research work. The mathematical model of HP Pump which was transformed to simulation program was validated with an open literature data with maximum percentage error of 1.42% against the benchmark percentage error of 10%, which has proven the implementation validity of the program. The analysis revealed that, HP Pumps of KRPC power plant have more energy and exergy efficiencies at design condition than in operating condition, and more energy is lost and more exergy is destroyed at operating condition than in design condition. These are due to faulty control system of the power plant.

Consequently, the KRPC power plant should always be run at design condition, otherwise the control system of the plant should be in good condition. The management of the company will be well guided in terms of carrying out maintenance in the plant. It is further expected that researchers, instructors and experts of energy science and engineering will find this research work useful.

ACKNOWLEDGMENT

The authors would like to thank Kaduna Refining and Petro-chemical Company, Nigeria for the approval to embark on this research study in the power plant and utility (PPU) department. The authors will not hesitate in appreciating the contributions of Mr. Jay Thakkar, Mr. Vinit Munjani and Ms. Jothsna Sri Kathayani Chillimuntha during this research work. Also, the authors will not forget to express their gratitude to Dr. Parak Sangani, the Provost, P P Savani University for his support.

REFERENCES

- [1.] Ibrahim, T. K. and Rahman, M. M. (2014). Effective Parameters on Performance of Multipressure Combined Cycle Power Plants. *Advances in Mechanical Engineering Hindawi Publishing Corporation*.
- [2.] Awad, O. I., Rizalman, M., Noor, M. M., Thamir, K. I., Yusri, I. M. and Yusop, A. F. (2018). The impacts of compression ratio on the performance and emissions of ice powered by oxygenated fuels: A review. *Journal of the Energy Institute* 91, no. 1 pg. 19-32.
- [3.] Haider, A. S., Baheta, A. T. & Hassan, S. (2014). Effect of Low Pressure End Conditions on Steam Power Plant Performance. *MATEC Web of Conferences*. Vol. 13 EDP Sciences.
- [4.] Laskowski, R., Smyk, A., Lewandowski, J. & Rusowicz, A. (2015). Cooperation of a steam condenser with a low-pressure part of a steam turbine in off-design conditions. *American Journal of Energy Research*, 3: 13-18.
- [5.] Kaduna Refining & Petro-chemical Company (KRPC), (2022). Available from: <http://www.nnpcgroup.com/nnpc-group/krpc> (Accessed on 5th February, 2022).
- [6.] Elghool, A., Firdaus B., Thamir, K. I., Khairul H., Hassan, I., & Daing M. N. D. I. (2017). A review on heat sink for thermo-electric power generation: Classifications and parameters affecting performance. *Energy conversion and management* 134 pg. 260-277.
- [7.] Yusof, A. A., Saiful, A. S., Syarizal, B. & Suhaimi, M. (2018). Simulation of System Pressure Impact on the Water Hydraulic Hybrid Driveline Performance. *CFD Letters* 10, no. 2 pg. 59-75.
- [8.] Python programming language meaning, (<https://whatis.techtarget.com/definition/C-Sharp>). Accessed on 18/06/2022.
- [9.] Zoder, Marius, et al. (2018). Simulation and exergy analysis of energy conversion processes using a free and open-source framework—python-based object-oriented programming for gas-and steam turbine cycles. *Energies* 11.10: 2609.
- [10.] Kumar, A., Nikam, K. C. and Behura, A. K. (2020). An Exergy Analysis of a 250 MW Thermal Power Plant. *Renewable Energy Research and Application* 1.2: 197-204.
- [11.] Pattanayak, L., Biranchi N., Padhi, B. K. & Bibhakar K (2019). Thermal performance assessment of steam surface condenser. *Case Studies in Thermal Engineering* 14: 100484.
- [12.] Bataineh, K., & Khaleel, B. A. (2020). Thermodynamic analysis of a combined cycle power plant located in Jordan: A case study. *Archives of Thermodynamics*, 95-123.
- [13.] Ahmadi, G. R., & Toghraie, D. (2016). Energy and exergy analysis of Montazeri steam power plant in Iran. *Renewable and Sustainable Energy Reviews*, 56, 454-463.
- [14.] Mohammed, M. K., Al Doori, W. H., Jassim, A. H., Ibrahim, T. K., & Al-Sammaraie, A. T. (2019). Energy and Exergy Analysis of the Steam Power Plant Based On Effect the Numbers of Feed Water Heater. *Journal of Advanced Research in Fluid Mechanics and Thermal Sciences* 56, Issue 2, pg 211-222.
- [15.] Kumar, Ravinder, et al (2019). A simulation model for thermal performance prediction of a coal-fired power plant. *International Journal of Low-Carbon Technologies* 14.2: 122-134.
- [16.] Tokyo Shibaura Electrical Inc. (1981). *Operating manuals for Steam Generation Facilities, Power Generation Facilities and Utility Facilities of Kaduna Refining and Petrochemical Chemical (KRPC) Limited*. Japan: Ishikawajima-Harima Heavy Industries Co. Ltd.
- [17.] Patel, S. S. L. and Agrawal, G. K. (2019). Investigation of influencing process parameters to energy and exergy efficiencies of a coal fired thermal power plant using cycle tempo. *International journal of computer sciences and engineering*. Vol. 7 (3), E-ISSN: 2347-2693, pg. 99.
- [18.] Pilankar, K. D., & Kale, R. (2016). Energy and Exergy Analysis of Steam and Power Generation Plant. *Int J Eng Techn Res*, 5, 344-350.