

Scrolling Display

GSM based Messages Crolling Led Display

Tahseen Ahmad, Vivek Kumar, Punit Ranjan Yadav
(Student) Department of Electrical Engineering,
Greater Noida Institute of Technology,
GreaterNoida.

Nikhil Kumar Gupta
(HOD) Electrical Engineering Department
of Greater Noida Institute of Technology,
GreaterNoida

Dr. Dhiraj Gupta
Director of Greater Noida
Institute of Technology,
Greater Noida.

Abstract:- Now a days GSM Based scrolling LED light displays is very largely used display. Which is being used in the field like railway buses and other vehicles displayed their destination and source from where they have got started and the path followed by the vehicle to reach their destination. Similarly, some other uses are on the station, platform and airport etc. To display the message. The visibility of LED light is very good which is the best advantage of LED light. Due to availability of LED lights of different colours it excites us to work on that. Due to having different colours of LED it becomes very attractive. And having different colours its wave length are also different which make them good looking. Usually, we use 230 volt alternating source of supply to operate the LED scrolling light. This ac source is not directly fed to the scrolling light, by the use of rectifier circuit like centre tap and bridge rectifier and filter circuit. We convert the source into dc source and fed to the scrolling LED display. And the level of voltage is decrease by use of controlled rectifier and chopper circuit.

Keywords:- GSM modem, Display board, Microcontroller, Assembly language etc.

I. INTRODUCTION

Before the invention of Semiconductor devices and microcontrollers, displaying a message was very cumbersome task, people used traditional method of wooden notice boards. By the advancement of technology & invention of microcontrollers, digital notice boards came into the market, many colleges, banks, railway stations, cinema halls started using scrolling LED display. Unit design was very compact and easy to handle. It is made of LEDs connected together with specific number of rows and columns arranged in a matrix configuration. Panels are divided in small standard size panels containing some sort of ratio of LED such as (8x8), (10x10) and so on. This arrangement makes easy to choose any size required for the purpose which can be manipulated as desired. But it has also some limitation, displaying a simple message on scrolling digital notice boards may be terrible and need someone skilled having knowledge of computer & program writing. Moreover, if the message presently being displayed need any modification or change at the same time, a personal computer is needed to connect with notice board microcontroller and a new message could be installed to the

display board. If there are more than one display boards same process needs to be done which is time consuming. This complexity can be eliminated from the system introducing GSM modems (Global System for Mobile communication). To make LED scrolling display more portable. GSM phone is used instead of bulky Keyboard and laptops. GSM based LED display consist of a receiver and message decoder which can be programmed using SMS.it visualize the MIN (Mobile Identification Number) and display the message after code conversion. with help of this device Scrolling message can be controlled easily and can be updated through SMS using simple mobile phones from anywhere under the range of wireless network. This idea of message display eliminated the tough task of programming and reprograming the microcontroller every time it needs to be changed. It also saves time and threat of physical damage to the equipment. GSM system is popular because it provides flexibility to display a new flash message or any announcement instantly thus avoiding any delay as faced in Programmable. Now a days GSM based display boards are being used everywhere from public transportation to shopping malls, High-way sign to the traffic signs. Apart from GSM based LED scrolling message display, several works have also deployed GSM for monitoring and Controlling purpose such as GSM based Street light controlling system, Vehicle tracking system using GSM modems, Vehicle parking slot booking system using GSM and RFID (Radio frequency identification). This Project uses a GSM modem at the display side to receive SMS, a microcontroller to derive the LED display along with this a Power supply unit and supporting hardware.

II. DESCRIPTION

This project explains each development step we took for designing the GSM based notice board by integrating features of all hardware components used. Each module is reasoned out and placed carefully, then making the unit to work best. The speed of the display can be controlled through the software and the message is displayed as required. received message on the LCD. Here we use 8051 as a microcontroller with 5v DC Power supply. The main hub/heart of this synopsis is GSM modem and it works on GPRS AT commands.

III. WORKING & CONSTRUCTION

The main motive of this research is to replace presently used display system with automatically driven GSM based

display system. A receiver means GSM MODEM is designed which is programmable from a specified Mobile phone. The sender sent the information through transmitter (mobile phone) which is to be displayed. The sent information is received by microcontroller then it is verified by generated unique code (MIN - Mobile Identification Number) and displayed on LED based display board. In this research, we made an effort to advance the display board system with microcontroller and enhance the display board in place of insignificant displays that are in used that makes our project very attractive and awesome.

To know about it's working, first we all have to familiar with its elements that are used in this research work. They are described below-

Components:

- GSM Modem
- SIM
- LED
- Microcontroller
- Level Shifter
- Voltage Regulators

We shall discuss these components in detail

- GSM Modem:



Fig. 1 : GSM Modem

GSM is nothing but a Global System for Mobile Communications chip that works as a medium between mobile phone (transmitter) and display board (receiver). It was flourished by the European Telecommunications Standards Institute (ETSI). It is the main part of the whole setup. The GSM modem is linked with power supply circuitry and communication interface (RS-232) with programmable devices. It can also be linked with dedicated modem devices like input-output serial ports, USB (Universal Serial Bus), Bluetooth or mobile phone that make it more compatible to use. Each GSM module is linked with an identical mobile phone. It is also implemented for voice and data services operate at the 850MHz, 900MHz, 1800MHz, and 1900MHz frequency bands. In case of interference between two information, GSM modem uses time division multiple access (TDMA) technique that gives it different time slot for each user at same frequency to send their information. GSM modem has very wide applications in many fields such as in transaction terminals, supply chain management, security applications, weather stations, and GPRS mode remote data logging.

- SIM:



Fig. 2 : SIM (Subscriber Identity Module)

SIM stands for Subscriber Identity Module. Initially, it was designed for mobile phone networking only (like calling and messaging, mostly for calling). But in this time, it is used for multipurpose. In GSM module, a slot is fixed for SIM to insert in. These days the dimension of SIM cards reduced radically and its functionality is increased. So dual SIM handsets are also available in market in which we can use two different SIM cards. SIM can also be used as storage for phone contacts, messages, roaming information across different networks, voice call records and many more data services. Presently mobile payments are done using mobile phones that can't be possible without SIM that's make it more popular. There is no issue with SIM cards when it is replaced from one mobile phone to another. It will perform the same task that it was doing in previous mobile phone. So, it is easy to change mobile phone or handset using the same mobile number.

- LED:



Fig. 3: LED Display

Light Emitting Diode, in short LED is a semiconductor device based on the Electric Luminescence principle. It has no moving parts, only made for solid materials. So often designed into transparent body. It is commercially used device for screening the display board. When LED is supplied from its two semiconductor coated terminals then it starts emitting light without heating that reduces the problem of heating in electronic components. LED based display consist of a number of LEDs connected closely to each other. By changing the value of each LED's brightness, a image is form that is the our required output displayed on display board. The image form has brilliance light intensity. This type of display is more efficient and less power consuming. For designing a LED display board following factors should be already known such as the display type, colour, size, brightness, and the number of LED required for that particular display board.

- **Microcontroller:**

Microcontroller is a small device. Which controls the particular operation of system. Microcontroller consist of RAM, ROM, Timer, Counter, Oscillator circuit, digital to analog converter and analog to digital converter. All the components and functional block design on a single chip. Microcontroller is also known as complete system or system on chip or computer on a chip because of all the peripherals are design on single chip. Peripherals are chosen according to applications. It is used to performed particular task. It is widely used in GSM Module. Microcontroller based system is very reliable. All these features are available in 40 pin IC. We have used microcontroller ATMEGA32. It is a 8 bit high performance microcontroller with low power Atmel Pico power 8-bit AVR RISC-based microcontroller which combines 32KB ISP flash memory with read-while-write capabilities. , 1024B EEPROM, 2KB SRAM, 23 general purpose I/O lines, 32 general purpose working registers, three flexible timer/counters with compare modes, internal and external interrupts, serial programmable USART, a byte-oriented 2-wire serial interface, SPI serial port, a 6-channel 10-bit A/D converter (8-channels in TQFP and QFN/MLF packages), programmable watchdog timer with internal oscillator, and five software selectable power saving modes. The device operates between 1.8-5.5 volts.

- **Level Shifter:**

A level shifter is a circuit used for shifting a signal from a lower level to higher level and vice-versa. Basically, a level shifter is a very simple circuit. It is use for compatibility between the integrated circuit with different voltage level most usual level voltage is 1.8V, 3.3V and 5.0V. We have to use MAX232 it is an IC that’s convert the signal from an RS-232 serial port to signals suitable for use in TTL compatible digital logic circuits. The MAX232 is a dual driver/receiver and typically converts the RX, TX, CTS and RTS signals. The drivers provide RS-232 voltage level outputs (approx. ± 7.5 V) from a single + 5 V supply via on-chip charge pumps. This makes it useful for implementing RS-232 in devices that otherwise do not need any voltages outside the 0 V to + 5 V range, as power supply design does not need to be made more complicated.

- **Voltage Regulators: -**



Fig. 4

A voltage regulator is an electronics device. Voltage regulators take variable and unstable input voltages and convert them to higher or lower constant output that matches the voltage and current needs of an electronic circuit. Basically, regulators of the linear IC type simply drop down the source to the desired level a voltage regulator may use a simple feed forward design or may include negative feedback

it may use an electromechanical mechanism or electronic component. Electronic voltage regulators are found in devices such as computer power supplies where they stabilize the DC voltages used by processors and other elements.

IV. SOFTWARE USED

Many software has been used for programming and interfacing of the micro controller to GSM modem SIM 300 as well as LED display. They are as follows:

- A. AT Commands
- B. Hyper Terminal

We shall also discuss the applications and their use in the project.

- A. *AT Commands:*

AT commands are instructions used to control a modem. AT is the abbreviation of Attention. Every command line starts with "AT" or "at". That's why modem commands are called AT commands. Many of the commands that are used to control wired dial-up modems, such as ATD (Dial), ATA (Answer), ATH(Hook control) andATO (Return to online data state), are also supported by GSM/GPRS modems and mobile phones. Besides this common AT command set, GSM/GPRS modems and mobile phones support an AT command set that is specific to the GSM technology, which includes SMS-related commands like AT+CMGS (Send SMS message), AT+CMSS (Send SMS message from storage), AT+CMGL (List SMS messages) and AT+CMGR (Read SMS messages).

- B. *Hyper Terminal:*

Hyper Terminal can be useful in diagnosing whether a connection problem is due to modem/line issues or dial-up networking issue, partly because it bypasses dial-up networking when dialling a POP. It is also capable of directing commands to the modem (ATi), there by providing a means of collecting valuable information about the modem properties such as the chipset, BIOS and more. Hyper Terminal can therefore be used instead of "More Info" or "Query Modem" on the Diagnostics tab of the Modem Properties in Windows.

V. BLOCK DAIGRAM

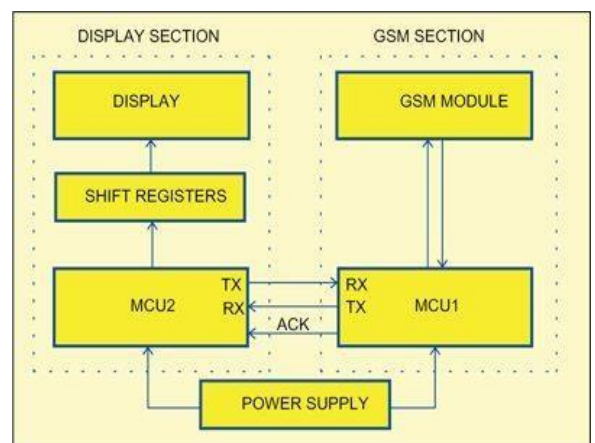

VI. FEATURES OF LED DISPLAY

Microcontroller based scrolling display has following features:

- The message to be displayed is stored in memory and the message length to be displayed is limited only but free memory space of the microcontroller.
- The running speed of message can be increased or decreased by pressing switches.

VII. FUTURE ENHANCEMENT

- Multiple language message display can be another variant in this model. The message can be first received, displayed in standard language. The same message can be translated to required language and the message can be displayed.
- In upcoming future, we can add more memory and high-end microprocessors to implement larger words and characters which will make it very easy to convey longer messages.
- We can use Red Led as a power indicator which will let us know that our system is properly plugged in or not.
- One thing for sure as upcoming trend IOT, we can add more (IOT) components to make this system more reliable.

VIII. CONCLUSION

By introducing the concept of wireless communications technology. In this communication make fastest growing and more efficient. Its efficiency is high so that we can display the message with less error. The GSM base LED display can be easily integrated with all general-purpose display board and various company created has been practical use like a notice board etc. GSM Based Led notice board collaboration of many software and hardware. It is very easy to operate consumes less power. This is paper based on GSM wireless technology. This technology can avoid paper work, reduce human efforts in all the industries, college and train. This GSM board project is a remote notice board with modem connected, so that display message, they will send SMS in our mobile phone. This project mostly used to police or army to display in something crucial within a matter of seconds and send the information. Using GSM mobile we can send to message to any distance location, from any part of the world. Multiple users are authorized to update notice on the electronics notice board. There no printing and photocopying cost. So that thus save time energy and finally our environment.

IX. ACKNOWLEDGEMENT

We would like to thank all the important people who have helped us in completing this paper. We would like to thank our H.O.D of Electrical Engineering Department Mr. Nikhil Kumar Gupta for providing us an opportunity to work on the project GSM Based LED Scrolling Display Board. We sincerely thank our project guide Dr. Dhiraj Gupta, Department of Electrical Engineering whose help, stimulating suggestions, knowledge and experience helped us at all the time during the study and analysis of the project.

REFERENCES

Form internet source

- [1.] www.slideshare.net
- [2.] www.Amvitech.com
- [3.] www.ukessays.com
- [4.] www.republication.com
- [5.] www.youtube.com