

Design and Construction of a Microcontroller Based Pulse Rate and Temperature Monitor with GSM Module

A. E. Amoran¹, A. S. Oluwole², and E. Olubakinde³

^{1,2}Department of Electrical and Electronics Engineering, Federal University Oye Ekiti, Nigeria

³Department of Electrical and Electronics Engineering, Federal Polytechnic, Ile-Oluji

Abstract:- The paper describes the development of a temperature and pulse rate monitoring with GSM module using microcontroller. Telemedicine is the practice of medicine remotely and the quick use of medical information to improve patient's health. The paper is aimed at developing a low cost, portable Global System for mobile Communication (GSM) module based temperature and pulse rate monitor capable of monitoring patients temperature and heart beats especially for old people who can't move around so as to draw the attention of medical personnel in case of emergency. The temperature DS18B20 and pulse rate MAX30102 sensors takes temperature measurement and pulse rate(which counts the pulse per minute) respectively and the readings from these sensors are converted to digital data employing an analog to digital converter (ADC) which is proper for wireless transmission using Short Message Service (SMS) messages through Global System for Mobile Communication (GSM) modem. The results are displayed via Liquid Crystal Display (LCD) and sent via GSM module to a pre-programmed phone number of medical experts or close pre-programmed phone number. The microcontroller is the central processing unit and it interpretes the integrated circuits then sends the data through to other components of the system. The source code is written in programming language using software and stores data in the microcontroller as the central processing system of the temperature and pulse rate. The microcontroller will receive the data and process the data in which the results will be displayed through the LCD and GSM.

Keywords:- Temperature, Pulse Rate, GSM Module.

I. INTRODUCTION

Telemedicine is the act of remotely collecting medical information to enhance patient's health condition and it a combination of information technology and Telecommunication Engineering for medical purposes (Joyce and Rachel, 2011). It a way to provide medical services involving far distance between a patient and his doctors. Health related issues and its indicators are essential to man, his existence and influence. Thus, seeking for improved system that can help health indicators time and location no withstanding so as to ensure timely recuperation

from abnormalities and cater for emergencies. A huge number of medical conditions can be detected from variations in one or more of the vital signs. Vital signs derive their relevance from the fact that they can be considered as a pointer to patient's health. Any setback in the measurements of these vital signs indicates an abnormality in the health condition of the patient. The specialized devices for measuring these vital signs are not compact and cannot be easily found. Hence, the need for a potable pulse rate monitor and mobile phone as a diagnosing tool.

According to Joyce and Rachel (2011) Pulse rate, Respiratory rate, Blood pressure and Body temperature are four standard vital signs in most medical settings and health related devices have been developed over time by experts to handle some of these vital signs for monitoring purpose. Thus, health monitoring devices has been developed such that it has become portable and wearable due to advancement in sensor and wireless communication technology. However, adding more sensors into the device can increase its weight and size thereby defeating the purpose of the device. Besides that, a device interface needs to be created on the computer to analyse, process and display the data sent by health monitoring device.

For a decade now, portable (small) devices that monitor health have increased a research interest in this area as it captures many researchers' interest, Rana Biswarup (2015) and Allen (2007). On the basis of the development and growth in sensor technology and wireless communication systems, there are numerous opportunities for innovations by researchers in health monitoring systems to improve the life of people, (Allen, 2007). Recently, there are a few systems providing a continuous health monitoring service for patients. A portable wireless technology heart rate or pulse rate monitor is a personal device which helps in the measurements of the pulse rate for analysis at any time and any place. Development in the wireless technology now allows the creation of various remote control systems, one of which is the Temperature and Pulse Rate monitoring concept.

II. LITERATURE REVIEW

Mohammad Faaiz, 2008 developed a heart rate monitor based on Bluetooth and sensor. The wireless transmission to a receiver which displayed the heart rate (in beats per minute) and the bluetooth technology for data communication with a terminal computer but the constraint of this work is that the distance between the computer and sensor is short, less than 20 meters which is difficult to be implemented in practical implementation.

(Javadpour et al., 2016) designed and constructed a temperature monitoring system. The work consists of some thermometers (wireless) with each of the thermometers having a transceiver (wireless) unit working at a frequency of 2.4GHz with an accurate temperature (digital) sensor and a microcontroller. The thermometers are supplied with distinct identification codes that enables the system to note necessary measurements. The system analysis during evaluation shows a good condition with a little fluctuation level below 0.25°C. The mean square error of the system in comparison with mercury thermometer is found to be 0.357°C. The results reveal that the thermometers (wireless) can also be connected to a node (central) from a point of approximately 30 meters apart with no termination in communication.

(Q. Gong et al., 2015) design a system for pulse signal detection using Bluetooth for data transmission. It is made up of an Arduino microcontroller board, a pulse sensor, a PC management platform and Bluetooth modules. After the signal has been filtered and amplified, the signal from the pulse is sampled with the help of a built-in Analog to Digital Converter (ADC) of the microcontroller. Processing of data occurs on the pulse signal in the Arduino microcontroller board. This happens after the pulse signal has been digitalized so as to calculate the time between heartbeats and the pulse rate. The results calculated is transmitted to the PC management platform through the Bluetooth module while the PC management platform

displays the pulse signal and the result on the screen with the aid of software (processing software).

(Zheng et al., 2009), developed a system which monitors person's health status and gives notifications for medical attention in case of emergency automatically in a real-time. It makes use of tiny wearable sensors for the collection of user's vital signals. Also, it uses wireless (Bluetooth) device to transfer the data (sensory) to a mobile phone for data storage and analysis. In addition, (Nasir et al., (2017), proposed a temperature monitoring system based on 1-wire protocol communication and PIC microcontroller. The system employed a digital temperature sensor DS18B20 having distinct serial code identifier of 64-bit that permits many DS18B20s to operate on the single 1-Wire bus thereby making it possible for a PIC microcontroller to control multiple DS18B20s spread over a great area. The results are accurate when compared with that of a mercury and a digital thermometer. However, the system's deficiency is temperature data storage.

III. METHODOLOGY

3.1 Design for the Circuit

The Block diagram for the temperature and pulse rate monitoring system with GSM module design is shown Figure 1. There are four blocks namely the power unit block which contains the power supply, the input block which contains the pulse rate sensor as well as temperature sensor DS18B20 and the output block which contains the GSM module and LCD module. The pulse sensor and temperature sensor results will be processed by the Arduino UNO microcontroller. Therefore readings are displayed on the LCD as well as an SMS is sent to the designated phone number. Figure 2 shows the circuit diagram of temperature and pulse rate monitoring system with GSM module. The circuit uses 5volts of Arduino UNO. 220volts enter the transformer but the transformer steps it down to 12volts. The 12volts on getting to the voltage regulator is regulated to 5volts and pass it across to the microcontroller.

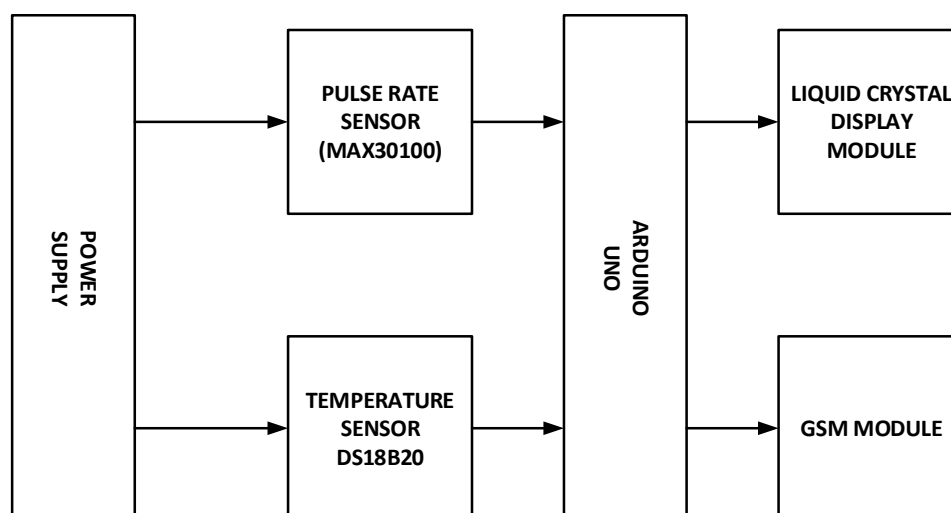

FIGURE 1: Complete Block Diagram

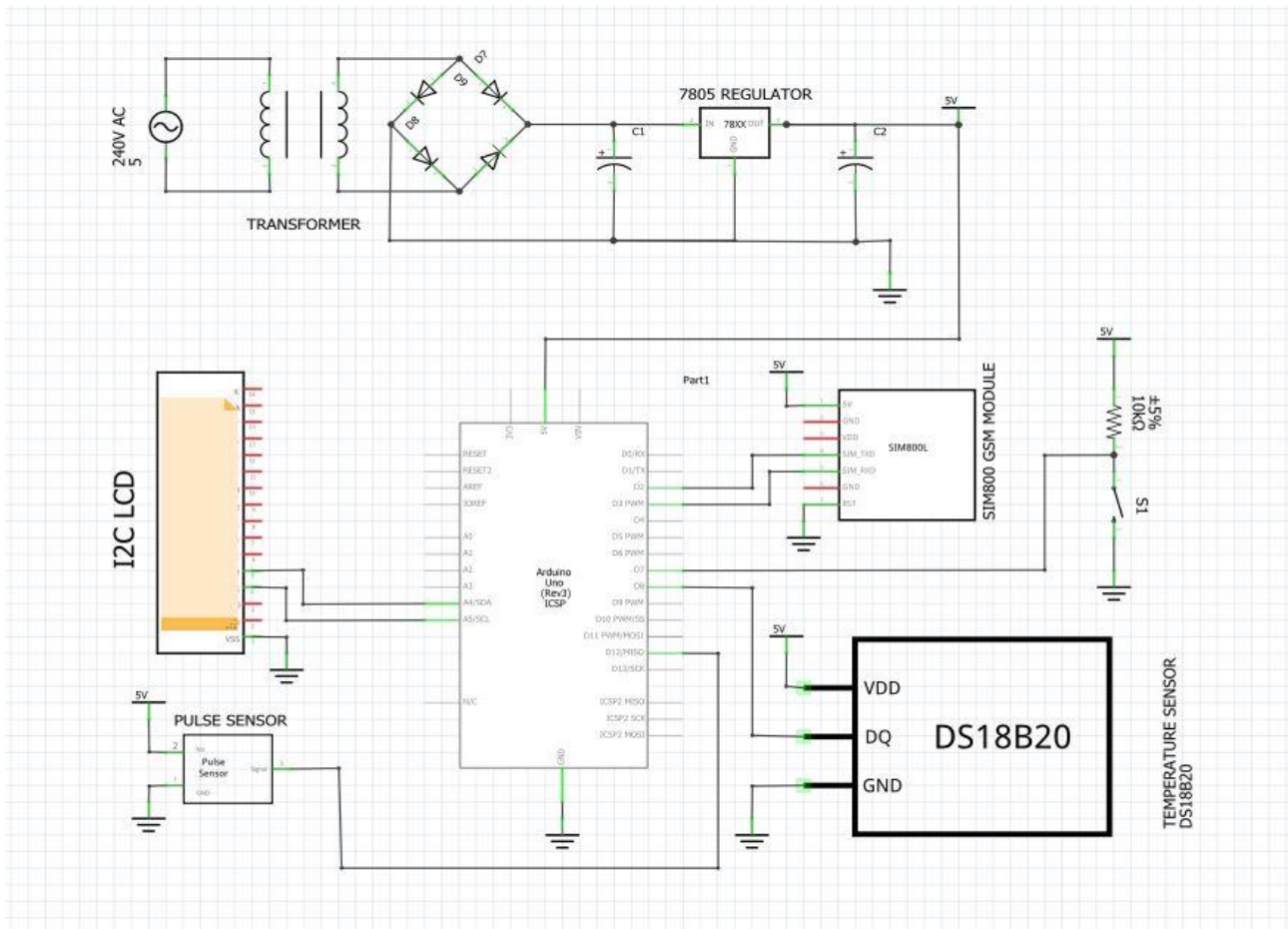

Figure 2: Block diagram

1.2 Components of the Block Diagram

3.2.1 Power Supply Section

This section consisted 12V/2A step down transformer, a bridge circuit, a capacitor and voltage regulator. The input supply to the transformer which is 220/50Hz is rectified to converts the alternating current(a.c.) to a direct current (d.c.) voltage. The voltage regulator regulates voltage to give a voltage of 5Vdc required as charging voltage for the cell. D.C. voltage is isolated from the mains by the transformer. From the rating, it steps down 240v input to 12v before delivering it to the input of the bridge rectifier. The rectifier circuit is made up of four diodes configured into a full-wave bridge rectifier. The regulator provides regulated and stable d.c .voltage (5v±0.1%). This output drives all the components used for this design. The capacitor served as filter to remove surges that appeared on either the input or output of the supply.

3.2.2 LCD MODULE

The LCD (Liquid Crystal Display) is the screen where readings obtained by the sensors and processed by the microcontrollers are displayed. The LCD is connected to pins 4 & 5 of the ARDUINO UNO microcontroller.

3.2.3 GSM Module

The GSM module used in this paper is SIM800C. The SIM interface supports a SIM card of 1.8V - 3V. The GSM Module was used to interact with microcontroller and the

GSM network and it in turns sent pulse rate and body temperature to the pre-programmed phone number. Thus enabling medical personnel to remotely monitor patient.

3.2.4 Mobile User

The mobile user is the pre-programmed phone number that is able to send and receive an SMS. The SMS is sent to these pre-programmed numbers and it the duty of the microcontroller to give control signal that instructs the GSM Module to send an SMS remotely over the GSM network. The SIM card is inserted into the hardware.

3.3 Design of the Software component

Software design controls the whole design through program used to operate the device. The system operation follows the following steps:

1. Start by powering
2. Setup display
 - i EEPROM initialization to keep Receiver phone number
 - ii GSM module(SIM800C) Configuration & Initialization
 - iii Heartbeat module(MAX30102) Configuration and initialization.
 - iv Digital Temperature (DS18B20) Configuration& initialization
 - v Read GSM module
 - vi If new phone configuration received,
 - a. Save the phone number to EEPROM
 - b. Delete all messages from GSM module

- c. Send Acknowledgement message to new phone number
- vii Read Phone number from EEPROM
- viii Loop
 - a. If button Pressed
 - b. Read heart rate
 - c. Read Body temperature
 - d. Display both the body temperature & Heart Rate on the LCD
 - e. Send both the body temperature & Heart Rate to the user via sms.
- ix. End loop
- x. END
- xi. Power off

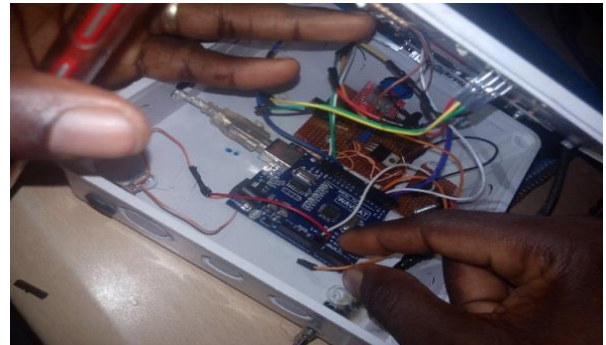

Fig 3 construction and packaging of the system

3.4 Comparison of the designed device and Digital Thermometer

Table 1 summarizes the testing of the designed temperature and pulse rate monitor on ten respondents.

S/N	GENDER	AGES (YEARS)	PULSE RATE (BPM)	SYSTEM TEMPERATURE (°C)	DIGITAL(°C) THERMOMETER
1	Male	14	85	37.0	37.0
2	Female	18	72	36.8	36.7
3	Female	20	77.0	36.5	36.8
4	Female	21	73.0	36.9	36.9
5	Male	21	75.0	37.2	37.0
6	Female	22	78.0	37.2	37.2
7	Female	22	77.0	37.2	37.3
8	Male	25	75.0	36.8	36.8
9	Male	26	86.0	37.2	37.2
10	Male	32	82.0	36.9	36.8

IV. RESULTS AND DISCUSSION

The temperature and pulse sensor with GSM module has been designed and it is a little different from both Javadpour et al., 2016 and Mohammad Faaiz, 2008 which designed separately wireless temperature monitoring based on 2.4GHz and heart rate monitor respectively. Also, this design is similar to Zheng et al., 2009 which both are capable of sending notifications for medical attention in case of emergency automatically in a real-time. This designed combined both temperature measurement and pulse rate monitoring and it is also capable of sending message to health officers and families in case of emergency.

V. CONCLUSION

The measurements were taken at 30 secs time-frame for both pulse sensor (MAX30102) and temperature sensor (DS18B20). As a result of the tests carried out on all correspondents as shown on Table 1. The limitations of this system are Minimum requirement of signal quality of 7dB, inconsistency of service from network providing companies and no in-built battery.

REFERENCES

- [1]. Hampton, J. R., (2003) ‘The ECG in Practice,’ *Churchill Livingstone*.
- [2]. Mohammed, I.S., (2016) “Remote-Controlled Microcontroller-Based Temperature System: An Economical Design”, *International Conference on Industrial Engineering and Operations Management (IEOM)*, pp. 2520-2525.
- [3]. Nasir, I.A., Abdurhman, A.B., Alhashmi, S.A., and Mohammed, H., (2017) “Design and Development of a Temperature Monitoring System Based on PIC Microcontroller and 1 Wire Communication Protocol,” *Journal of Pure & Applied Sciences (JPAS)*, vol.16, no.1, pp. 813.
- [4]. Allen J., (2007), “Photoplethysmography and its Application in Clinical Physiological Measurement”, *Physiol Meas.* vol. 28, No. 3, pp. 1-39.
- [5]. Rana B., (2015), “Analysis of PPG and ECG”, *LAP Lambert Academic Publishing*.
- [6]. Oghogho, I., (2012) “PC Based Temperature and Monitoring Alarm System”, *Indian Journal of Scientific Research (IJSR)*, vol. 3, No. 2, pp. 17-20.
- [7]. Javadpour, A., Memarzadeh-Tehran, H., and Saghafi, F., (2016) “Temperature Monitoring System Incorporating an Array of Precision Wireless Thermometers,” *International Conference on Smart Sensors and Application (ICSSA)*, pp. 155-160.

- [8]. Q. Gong, G. Li, P. Sun, and Y. Pang (2015), “Design and Implementation of Pulse Signal Detection System Based on Bluetooth Transmission,” *Int. J. Control Autom.*, Vol. 8, No. 7, pp. 141-148.
- [9]. Edwards, S., (1993) “Heart rate Monitor Book”, *Leisure Systems International*.
- [10]. Várady, B., Benyó, Z., and Benyó, B., (2002) “An Open Architecture Patient Monitoring System Using Standard Technologies,” *IEEE Transactions on Information Technology in Biomedicine*, vol. 6, No. 1, pp. 95-98.
- [11]. Wu, W., Cao, J., Zheng, Y., Zheng, Y.P., (2009) “WAITER: A Wearable Personal Healthcare and Emergency Aid System,” *IEEE International Conference on Pervasive Computing and Communications*, pp. 680-685.