

# Effect of Service Quality on Customer Satisfaction Through Customer Value in PDAM Kota Makassar

## (Customer Approach in Developing Clean Water Product Services to Customers)

\*Wahyudi Putera<sup>1</sup>  
Department Economic Education  
District Government Maros

\*Romansyah Sahabuddin<sup>2</sup>  
Department Management  
Faculty of Economics State University of Makassar

\*Muhammad Rakib<sup>3</sup>  
Department Entrepreneurship  
Faculty of Economics State University of Makassar

\*Adianus S. Girikallo<sup>4</sup>  
Department of Engineering  
Akademi Maritim Indonesia, AIPI Makassar, Indonesia

**Abstract:-** This research design aimed to test whether factors such as service quality, customer value can affect customer satisfaction in PDAM Makassar City. The research was conducted in 8 (eight) sub-districts, namely Biringkanaya, Bontoala, Sangkarrang Islands, Makassar, Mamajang, Manggala and Panakkukang Districts, from January to October 2020. The population in this study were regular customers of Makassar City PDAM. The accidental sampling method is considered more suitable for this study. There were 250 respondents as the unit of analysis. The data collection method was carried out by distributing questionnaires, in-depth interviews, field observations and literature reviews. The analytical method used to test the research hypothesis is structural equation modeling (SEM) AMOS Vesion,-23. The results of the analysis show that there is a significant effect of service quality on customer value between service quality and customer satisfaction.

**Keywords:-** Customer, SEM, Service Quality, Customer Value, Customer Satisfaction.

## I. INTRODUCTION

### A. Study Background

Perusda (PDAM) of Makassar City is one of the largest distributors of clean water in Makassar City because it has proven clean and proper health and good service from its employees. Makassar City is located between 119 ° east longitude and 5 ° south latitude which borders the north with Maros Regency, east of Maros Regency, south of Gowa Regency and the west is the Makassar Strait. Makassar City has a topography with a land slope of 0-2 ° (flat) and a land slope of 3-15 ° (wavy). The area of Makassar City is recorded at 175.77 square kilometers. Makassar City has a temperate to tropical climate with an average temperature ranging from 26 ° C to 29 ° C. Makassar City is a city that is located close to the coast that stretches along the western and northern corridors and is also known as the “Waterfront City” in which

several rivers (Tallo River, Jeneberang River, and Pampang River) flow into the city. Makassar City is a low-lying stretch of land at an altitude between 0-25 meters above sea level. From this condition, Makassar City often experiences standing water during the rainy season, especially when it rains along with rising tide. The amount of water when it rains and the rising tide in the sea makes it important to manage clean water properly. From the importance of clean water management, the Government is the leading sector in thinking about the formation of a clean water sanitation management. Starting in 1924 a water management installation (IPA) was built by the Dutch East Indies government under the name Waterleidjding Bedrijf with an installed production capacity of 50 l / s, then during the Japanese occupation in 1937 it was increased to 100 l / s. After taking a long time, finally the Government in 1976 changed its status to (PDAM) from the Drinking Water Service to the Ujung Pandang Kodya Drinking Water Company in accordance with Perda No. 21 / P / II / 1976, with installed production capacity (PDAM) down to 50 l / d, due to age. In order to meet the increasing demand for water for the population of Makassar City, in 1977 the Panaikang II Water Treatment Plant (IPA) was built with a first stage capacity of 500 l / d. The effect of increasing consumption of clean water in Makassar City has an impact on the need for sufficient clean water for customers. These problems require serious attention from stakeholders to immediately formulate a clean water treatment strategy by developing clean water product services as a relevant strategy in the clean water sanitation sector to restore and revitalize clean water and clean water products that have the potential to increase the benefits of local communities and the Government. The area will clean water in increasing value and satisfaction to customers.

### B. Research Questions

- Does the quality of service affect the customer value of PDAM Makassar City?
- Does the quality of service affect the customer satisfaction of PDAM Makassar City?

- Does customer value affect the customer satisfaction of PDAM Makassar City?

### C. Research Objectives

Researching the level of service of "Clean water products" as a place for customers to get services for Perusda (PDAM) Makassar City clean water products

## II. LITERATURE REVIEW

Service is any activity intended or intended to provide satisfaction to customers, through this service the wishes and needs of customers can be fulfilled, especially customers of Perusda (PDAM) Makassar City where customers are divided into 3 (three) uses of clean water products, namely household consumption, business and business, while Norment, Wardrup and Callahan (2007) mention 6 (six) categories of clean water customer groups (PDAMs), including commercial, school, government, household, general social and special social groups. Various diverse market segments cause customers (especially entrepreneurs) to understand very well about clean water product services. Service is an activity that involves community participation, especially customers. However, the success of participation depends on the goals and ideology of each stakeholder. Mohan and Stokke (2000: 263). The role of the government to facilitate community participation, especially customers, is very urgent in relation to the sustainability of clean water product services. The service sector in the Perusda (PDAM) of Makassar City plays an important role in contributing to economic growth, especially regional income and job creation, clean water sanitation, cultural diversity, traditional parties, biodiversity, attractive clean water installation buildings, and wastewater treatment into water. clean water especially in Perusda (PDAM) of South Sulawesi Province in general and Makassar City in particular are known as profitable clean water sanitation treatment. Services that are translated into services to customers, especially various service models and embedded in all parts of the service called clean water product services to customers, clean water product functions in all aspects of life and various other functions, including value or 'value'. The existence of clean water products for the people of South Sulawesi Province, especially the City of Makassar, provides a very large value or benefit so that some people want to become new customers. To seize this opportunity, it is necessary to develop clean water products as a forum for the community to get clean water services that are good for daily consumption and as an implementation of better service development.

### A. Quality of Service

Dukic & Kijevcanin (2012) stated Service Quality. The orientation or personality or feeling includes: (1) Excellent is the standard of performance obtained. (2) Customers are individuals, groups, departments or companies that receive, pay for service outputs (services and systems). (3) Service is the main or complementary activity that is not directly

involved in the product manufacturing process, but emphasizes more on transaction services between buyers and sellers. (4) Quality is something that is specifically palpable or cannot be felt from the characteristics of the product or service. (5) Level is a statement on the system used to monitor and evaluate. (6) Consistent is that there is no variation and all services run according to the established standards. (7) Delivery is providing the right service in the right way and in the right time. In relation to business, service quality is manifested in 2 (two) things, namely in terms of service effectiveness in managing the organization. The second is related to the quality of services or goods provided to the attitude or response of customers / consumers. Then regarding what functions are carried out by employees / employees, this is explained as follows: The definition of BUMD includes 3 functions, namely: 1) implementing local government policies in the economic and development fields; 2) accumulating funds for development financing; 3) compilers of technical administrative policies in the fields of investment, promotion, investment cooperation, empowerment of BUMD and integrated licensing services. Several indicators related to service quality implemented by PDAM managers as the best service to their customers are as follows: tangibles, competence, reliability, responsiveness and courtesy.

Service quality is the ability to create information and communication that is different from others Tjiptono (2012). Tjiptono (2012: 28) defines service quality as an application process and finding opportunities to improve information processes. The ability to serve encourages someone's interest in managing information and communication in a professional manner. In service psychology, there are factors that affect the ability to serve that focus on characteristics (traits) in service in general and individually, such as locus of control. There are 5 (five) main characteristics of service quality, namely: a) timelines of service, b) service accuracy, c) politeness, d) convenience or convenience and convenience or comfort Suryana (2003). Services that are successful and run well are generally those who have competence, namely a person or organization that has good management of information governance and communication with the customer / consumer community Hamburg C, Hoyer & Fassnacht in Tjiptono & Chandra (2005: 145).

Economists and management on institutional drive for service quality, for example Rhett H. Walker, Lester W. Johnson & Sean Leonard (2006) with the title Re-Thinking The Conceptualization of Customer Value and Service Quality Within The Service-Profit Chain explain the results of research suggests that the profit-service chain is based on the premise that profitability for the company comes from customer satisfaction and loyalty, which, in turn, comes from an accepted sense of customer value. Furthermore, Shun Yin Lam, Vankatesh Shankar, M. Khrisna Erramili & Bvsan Murthy (2009) with the title Customer Value, Satisfaction, Loyalty and Switching Costs: An Illustration From A Business To Business Service explained that the results of the study

show that they support most of the hypotheses and in particular, confirm the role of mediating customer satisfaction as well as Yonggui Wang, Hing Po Lo & Yongheng Yang (2004) with the title *An Integrated Framework for Service Quality, Customer Value, Satisfaction: Evidence from China's Telecommunications Industry* explaining the research results show network quality is one of the most important drivers of service quality. Overall, customer value and customer satisfaction while customer sacrifice (including price) have a significant negative impact on customer value, and thus affect customer satisfaction and customer behavior intentions in an indirect and negative way.

### *B. Customer Value*

Every customer has the potential to have a role in the development of company / government organizations in various forms of activity (Kotler & Keller, 2012). Even though the customer has a role for the development of the company / government organization, that role can only be done at certain times. The role for this particular development in order to find answers to a problem is called art the science, while the expression of that role is known as a value.

Soerjono (2007: 151) says that values are an abstract conception that exists in humans, this is because values can be considered good and can also be considered bad. Value is a description of something that is desired, valuable, appropriate, and can influence the social behavior of every individual who has that value. Value is a description of something that is desired, valuable, appropriate, and can influence the social behavior of each individual who has that value (Lawang, 2005: 13).

Talking about the means or means in a value cannot be separated from the sacrifice element and the benefits that exist in someone who participates in determining the level of a value to be achieved, because the sacrifice and benefits of something are an incentive to customers to do something, that is also closely related to the needs (needs) of humans themselves. The goals desired by customers / consumers may differ from the goals of the company / government organization. According to Sweeney & Soutar (2001), entitled *"Consumer perceived value: The development of a multiple item scale"*, which develops several scales used to measure customer value. The measurements used in this study describe how consumers value a product in the functional aspects of performance (quality / performance value), value for money (price / value for money), pleasure or joy that arises after consuming a product (emotional value) and also the social consequences of what the product reflects on the consumer (social value).

In the process of customer value, there are 2 (two) theories, namely the profit and the benefits as suggested by Vanessa (2007: 36). The profit, in principle, looks at the benefits felt by customers / consumers in feeling the products produced by the company through physical attributes, service attributes and supporting techniques in producing products and

the benefits received by customers / consumers, namely the products produced. by the company is able to answer all the needs and desires of customers / consumers.

Various studies used in the customer value literature include: Christine G. Chi & Dogan Gursoy (2009) with the title *"Employee Satisfaction, Customer Satisfaction and Financial Performance: An Empirical Examination"* explains the results of the study show that although customer satisfaction has a significant positive impact on financial performance, employee satisfaction does not have a significant direct impact on financial performance. Furthermore, Ying Feng Kuo, Chi Ming Wu & Wei Jaw Deng (2009) with the title *"The Relationship Among Service Quality, Perceived Value, Customer Satisfaction and Post Purchase Intention In Mobile Value Added Services"* explained the results of the study showed that: (1) service quality positively affects perceived value and customer satisfaction; (2) perceived value positively influences customer satisfaction and post-purchase intentions; (3) customer satisfaction positively affects post purchase intentions; (4) service quality has an indirect positive effect on post-purchase intentions through customer satisfaction or perceived value; (5) among the dimensions of service quality, "customer service and system reliability" has the most influence on perceived value and customer satisfaction, and "content quality" ranks second; (6) the proposed model is proven by its effectiveness in explaining the relationship between service quality, perceived value, customer satisfaction, and post-purchase intentions in cellular value-added services and Martina G. Gallarza, Irene Gil Saura & Morris B.Holbrook (2011) with the title *The Value of Value: Further Excursions on The Meaning and Role of Customer Value* explains the results of the research showing several promising research streams to expand future knowledge in the field of customer value.

### *C. Customer Satisfaction*

The customer is one of the benchmarks of performance in non-financial organizations. There are various conceptual definitions of customer satisfaction used by previous researchers. According to Giese & Cote (2000) in their research, they have identified various conceptual definitions from the literature and from previous researchers about customer satisfaction. Based on several conceptual definitions, Giese, et al. Concluded that the three main components in the definition of customer satisfaction are the first, customer satisfaction is emotional and cognitive responses; second, responses are more focused on expectations, products, consumption, and experiences; all three responses occur after consumption, after selection and based on accumulated experience. According to Gunderson, Heide, & Olsson, (1996) that consumer satisfaction is a post-consumption evaluative assessment related to the quality of a product or service. Customer satisfaction is defined as overall satisfaction, namely the overall response to how satisfied and dissatisfied with the total product or service attributes are. According to Keith & Newstrom (1995), service quality affects customer

satisfaction, trust, customer retention and ultimately brings profit.

Kotler & Keller in Tjiptono (2012) argue that there are six customer satisfaction theories that are structured into three main perspectives, namely a psychological perspective (which includes cognitive dissonance theory, contrast theory, assimilation contrast theory, and adaptation level theory), economic perspective (utility theory), as well as a sociological perspective (alienation theory). According to Gursoy & Swanger (2007), the ability to respond quickly and effectively (time-based competition) and to meet customer needs has become a characteristic that determines the competitiveness and success of many companies. And there is a need for a method to measure the level of customer satisfaction, including (complaints and suggestions system) or a system of complaints and suggestions, (ghost shopping) or mystery shopper, (lost customer analysis) or analysis of lost customers (customer satisfaction survey) or satisfaction survey. customers (Kotler & Keller, 2012).

Perceptions of the quality of drinking / clean water customer service are felt by customers during and after obtaining clean / drinking water products. The performance of all attributes of drinking / clean water products affects customer satisfaction. Oliver (1999) argues that service quality is an antecedent to customer satisfaction regardless of whether the two constructs are measured in specific experiences or over time. Antecedents are things or events that occur or occur before other events and have events after them. The attractiveness of clean / drinking water products based on the conceptual framework used in this study includes (1) the attractiveness of drinking / clean water products in the form of conformity with customer expectations of product quality, (2) attractiveness of drinking / clean water products in the form of speed of service and (3) attractiveness of clean / drinking water products in the form of conformity with customer expectations of service quality. Their combination is integrated in one impression of the experience of clean / drinking water products that customers feel. The purpose of clean / drinking water products provided to customers is to achieve a level of satisfaction that will never be found in other places / companies. Subjective measurement of satisfaction is based on customer perceptions.

Various studies used in the customer satisfaction literature include: Suzana Dukic & Velida Kijevcanin (2012) with the title Service Quality As Determinant of Customer Satisfaction, explaining the results of the study show that service organizations operate in uncertain and volatile conditions. Furthermore, Gloria KQ Agyapong (2011) with the title The Effect of Service Quality on Customer Satisfaction In The Utility Industry-A Case of Vodafone (Ghana) explains the results of the study show that all service quality items are good predictors of customer satisfaction and Olu Ojo (2010) ) with the title The Relationship Between Service Quality and Customer Satisfaction In The

Telecommunication Industry: Evidance from Nigeria explains the results of the study show that service quality affects customer satisfaction and that there is a positive relationship between service quality and customer satisfaction.

*D. Conceptual Framework*

The problem of the need for clean / drinking water is a central theme in studying the clean / drinking water sector. The interaction between the manager and his customers is a reciprocal relationship and must be carried out according to good norms. Advances in science and technology in general and ICT in particular as well as the problem of globalization affect the balance of natural ecosystems, especially in the field of clean / drinking water to distribute to customers. Despite many attempts to theorize the role of value in the context of consumer decision making, researchers have shown different points of view on the value process. The antecedents and consequences of perceived customer value often differ across studies eg, Dodds, Kent & Grewal, 1991; Woodruff (1997). Ambiguity in the definition of customer value is another important subject for extensive study. In addition, several studies simultaneously consider customer value with variables considered important to explain consumer product evaluation. For example, perceptions of performance and satisfaction and their relationship to customer value, (return) purchase intention, and word of mouth have been neglected in previous value-based research. Therefore, this study is an attempt to test the model by considering these omitted, but important variables and relationships within a single framework. What is very important for this research is the initial integration of the various views on the consumer purchasing decision-making process which is reflected in the models of service quality, customer satisfaction, and customer value.

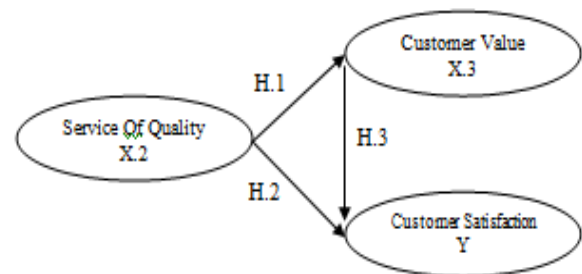

Fig 1.- Conceptual Framework  
Source: Author's Creation

Most of the attractiveness of PDAM managers comes from the analysis of the attractiveness of drinking / clean water in its presentation to the community as investigated using archival data. In conclusion, a systematic approach is important to understand the delivery of clean / drinking water and the attractiveness of customers. This approach is based on the fact that the delivery of clean / drinking water is very dependent on the availability of water resources and on the perception that customers own these resources. According to Rhett H. Walker, Lester W. Johnson & Sean Leonard (2006) is

a way of conceptualizing earnings services based on the premise that it is not an intrinsic property but rather an extreme attribute determined only by the customer. This is a powerful conceptualization in providing customers with a product or service through friends or relatives, it is designed by managers to provide the best service, especially for products to customers, both lower, middle and upper class without exception (David Garvin in McLeod & Schell , 2007).

**III. METHODOLOGY**

This research design aims to test whether factors such as: service quality can directly or indirectly affect customer satisfaction of PDAM Makassar City. This research is a quantitative method in which data is collected in numerical data. However, qualitative data in the form of information obtained from customers and stakeholders in company management is used to validate and confirm primary data. Primary data obtained from questionnaires distributed to respondents. The number of respondents in this study were 250 respondents. Secondary data were obtained from literature reviews, Perusda documents (PDAM),

The population in this study were the customers of Makassar City PDAM in the sub-districts / kelurahan in Makassar City in particular. While the sample is determined by non probability sampling technique, namely: convenience sampling. In this case every community / customers who meet and are deemed eligible and welcome to participate will become respondents. Therefore the sample is based on an easy to find person or element who is in a timely and accessible place and he or she is willing to provide answers to data collection instruments or questionnaires that are distributed to him. Then, the Accidental sampling method is used to obtain the appropriate number of samples. According to Malhotra (1993), it is suggested that the number of samples taken can be determined by changing the number of variables to 5, or 5 X to 10 X the number of variables. According to Tabachnick & Fidell (2007), 300 cases were suggested for factor analysis. The analytical method used to test the research hypothesis is Structural Equation Modeling (SEM) using AMOS Ver, -23 software. Each latent variable consists of five indicators per observed variable but after testing the validity and reliability, the remaining indicators are as follows:

No.	Research Variable	Research Indicators	Information
1.	Quality Of Service (X.2)	Competence (X2.2)	Valid
		Reliability (X2.3)	Valid
		Responsiveness (X2.4)	Valid
		Courtesy (X2.5)	Valid
2.	Customer Value (X.3)	Social Value (X3.2)	Valid
		Price Value (X3.4)	Valid
3.	Customer Satisfaction (Y)	Speed Of Service (Y.2)	Valid
		The conformity of customer expectations for service quality (Y.3)	Valid

Table 1: Research Variables and Indicators  
Source: Author

**IV. STUDI OF CASE**

*A. Confirmatory Factor Analysis on the Model*

Measurement The measurement model is how to measure the validity and reliability of the observed variables on latent variables. The following table presents the average value and the external loading of each indicator in each research variable. Based on Table 2, the result is that all indicators significantly measure each other's variables and have a loading factor value ( $\lambda$ ) > 0.5 and CR > 1.96) It shows that all indicators are declared valid and reliable. The analysis also shows that the indicator with the highest average in measuring its latent variables, customer value (Y.1) is an indicator of duration of stay (Y1.3) with an average value of 4.19. Likewise for the service quality variable (X.2), it was noted that the indicator with the highest average was Courtesy (X2.9) with an average value of 3.65. Last but not least is the variable of clean / drinking water customers.

For the satisfaction variable (Y.2), it is noted that the indicator with the highest average is the conformity of customer expectations for service quality (Y2.2) with an average value of 4.02. By looking at the results of the confirmatory factor analysis (CFA) both the independent and dependent variable research as tabulated in Table 2, confirms that the observed variables as a whole (indicators) significantly measure their constructs. These cases show a loading factor value ( $\lambda$ ) > 0.5 and CR > 1.96), therefore the CFA results on the research variables are valid and reliable and the SEM analysis process will then be continued.

No	Research Variable	Research Indicators	$\lambda$	S.E	C.R	Mean
	1	2	3	4	5	6
1.	Quality Of Service (X.2)	Competence (X2.2)	0.85	0.008	10.885	3.48
		Reliability (X2.3)	0.57	0.006	9.259	3.35
		Responsiveness (X2.4)	0.96	0.009	10.694	3.14
		Courtesy (X2.5)	0.74	0.007	10.470	3.48
2.	Customer Value (X.3)	Social Value (X3.2)	1.31	0.011	11.543	3.13
		Price Value (X3.4)	0.78	0.009	8.902	3.36
3.	Customer Satisfaction (Y)	Speed Of Service (Y.2)	0.03	0.06	0,414	3.46
		The conformity of customer expectations for service quality (Y.3)	1.51	0.012	12.204	3.75

Table 1: Research Variables and Indicators  
Source: Author

	Estimate	S.E	C.R	P
X3 ←	.386	.048	8.045	***
X2 ←	-.717	.207	-3.464	***
Y ←	1.181	.108	10.897	***
X2 ←	.057	.006	9.259	***
Y ←	.085	.008	10.885	***
X2 ←	.078	.009	8.902	***
X2.3 ←	.003	.006	.414	679
X2 ←	.151	.012	12.204	***
X2.2 ←	.131	.011	11.543	***
X2 ←	.074	.007	10.470	***
X3.4 ←	.096	.009	10.694	***
X3 ←				
Y.2 ← Y				
Y.3 ← Y				
X3.2 ←				
X3 ←				
X2.5 ←				
X2 ←				
X2.4 ←				
X2 ←				

**V. ANALYSIS RESULTS**

**A. Test assumptions. Structural Equation Modeling (SEM).**

Test classic assumptions before running a SEM analysis. The multivariate normality assumption test is fulfilled. To test the presence or absence of outliers, it can be seen with the Mahalanobis distance (Md). The test results show that statistically there are several observations that are outliers. However, the observational data was not excluded because the descriptive analysis showed that all indicators had a minimum and maximum value within the specified score limits, namely at least 1 and maximum 5. The test is carried out with the assumption of the Curve Fit linearity where the test results show that all linear models are significant for Sig> 0.05, thus concluding the assumption linearity has been met.

**B. Goodness of fit analysis.**

The results of testing the overall goodness of fit model will determine whether the hypothesis model is supported by empirical data given in Table 3a and Figure 2 below:

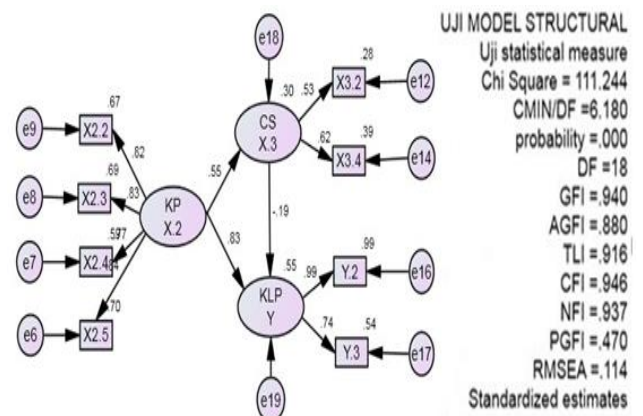

Figure 2: Model Structure  
Source: Proposed Model, 2020

Table 3a: Calculation of Regression Weight  
Source: Primary Data Processed, 2020

Criteria	Cut-Of-Value	Model	Information
Chi Square	Lower	111.244	Model Baik
p-value	≥ 0,05	0.164	
CMIN/DF	≥ 0,05	6.180	Model Baik
RMSEA	≥ 0,05	0.114	Model Baik
GFI	≥ 0,05	0.940	Model Baik
CFI	≥ 0,05	0.946	Model Baik
TLI	≥ 0,05	0.916	Model Baik

Table 3b: Overall Goodness Of Fit Analysis

The test results on the Goodness of Fit Overall show that there are 6 criteria that indicate a good model, namely Chi Square, CMIN / DF, RMSEA, GFI, CFI, TLI. According to

Arbuckle & Wothke in Solimun (2008), the best criterion used as an indication of the goodness of the model is that the Chi Square value is smaller and the DF is less than 2, and the RMSEA is below 0.08. In this study, the values of CMIN / DF and RMSEA have met the criteria for goodness of fit value. Therefore, the SEM model is supported and confirmed by the data.

C. Structural Equation Modeling Analysis

The second part of SEM analysis is the interpretation of the structural model. The relationship between the study variables and the value of the analysis results is summarized in Table 4 and Figure 3 to show direct and indirect effects.

No	Correlation	Coefficient	P-Value	C.R	Information
1.	X2 between X3	0.386	0.000	8.045	Significant
2.	X2 between Y	1.181	0.000	10.897	Significant
3.	X3 between Y	-.717	0.000	-3.464	Non Significant

Table 4: SEM Structural Model: Direct Effects

Source: Primary Data Processed, 2020

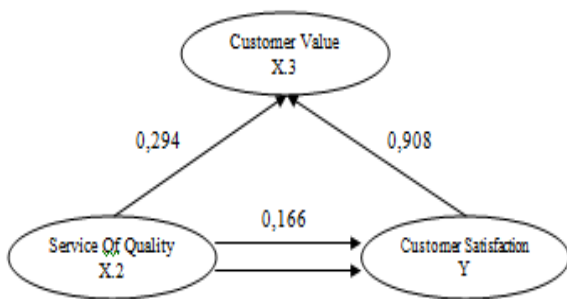

Figure 3: SEM Structural Model

Based on Table 4 and Figure 3, it is found that there is a significant direct influence between service quality (X2) towards customer value (X3). The correlation is characterized by a positive coefficient of 0.386 which is confirmed by  $C.R > 1.96$  for a significance level of 0.05, they indicate that a higher quality of service (X2) will increase the value of the customer value variable (X3). While the correlation of service quality (X2) to the customer satisfaction variable (Y) shows a positive coefficient of 1.181 which is confirmed by  $CR > 1.96$  for a significance level of 0.05, and customer value (X3) on customer satisfaction (Y) shows a negative coefficient of -717 confirmed by  $CR < 1.96$  for a significance level of 0.05, this indicates that the customer value (X3) variable does not significantly affect the customer satisfaction variable (Y).

This case argues that the quality of service that provides services does not absolutely increase customer satisfaction (Y). The correlation between customer value (X3) and customer satisfaction (Y) is positive and significant as indicated by the coefficient of 1.181 and  $CR 10.897 > 1.96$ . So it can be confirmed that there is a mediating effect of customer value (X3) on the effect of service quality (X2) on customer satisfaction (Y).

There is a significant effect between one variable and another, if the P-value is  $< 0.05$ , except for the X2 P-value between Y2, which is  $0.065 > 0.05$ , which indicates insignificance. In this study, there are two influences to be discussed, namely direct and indirect effects.

There is a significant effect between one variable and another, if the P-value is  $< 0.05$ , except for the X2 P-value between Y2, which is  $0.065 > 0.05$ , which indicates insignificance. In this study, there are two influences to be discussed, namely direct and indirect effects.

The Sobel test results show that the mediator variable (customer value) significantly influences the independent variable (customer satisfaction). The Sobel test results show a value of -3.464 and a CR value of  $2.91964463 > 1.96$ , and a p-value of  $0.00350431 < 0.05$  indicates that customer value (X3) mediates the effect of service quality (X2) on customer satisfaction (Y) Because the coefficient is negative and insignificant, the lower the increase in the value of X2, the lower the value of X3. In this case it can be illustrated that if the quality of service (X2) decreases by 1 unit, it will have an impact on an increase of 0.3464 (34.64%) on customer satisfaction (Y). Because the effect of customer value (X3) is not significant on customer satisfaction (Y), the function of the mediating variable is called incomplete.

D. Hypothesis and Analysis of Research Findings.

Based on table 5, the hypothesis and research findings can be explained as follows: the t-value is  $8.045 > 1.96$  and  $p < 0.05$ . This shows that H null is rejected and alternative H is accepted. This means that the variable service quality has a positive and significant effect on customer value. In addition, the regression coefficient value is 0.386, indicating that if X2 increases one unit, it has the potential to increase 0.386 X3, in other words if X2 increases 1% it will result in an increase of 38.6% X3. GFI's Goodness of fit Index is 0.940; CFI is 0.946 indicating that service quality plays an important role to provide a diversified service product excellence.

The influence of customer value on customer satisfaction. Based on table 5, the t value is  $-3.464 < 1.96$  and p-value  $0.000 < 0.05$ , in this case we do not agree with H null and take the alternative H (Ha), thus customer value has no significant and negative effect on satisfaction. Perusda customers (PDAM). The regression coefficient value is -717,

indicating that if the customer value decreases by 1 unit it will decrease the customer satisfaction value to -.717.

Effect of service quality on customer satisfaction. Based on table 5, the t value is 1.181 > 1.96 and the p-value is 0.000 < 0.05, in this case we agree with H null and take the alternative H (Ha), thus service quality has a significant and positive effect on Perusda customer satisfaction (PDAM). The regression coefficient value is 1.181, indicating that if the quality of service is increased by 1 unit it will increase the customer satisfaction score to 1.181. Perusda (PDAM) of Makassar City has many prospective service points, but the problem is the lack of knowledge and experience in managing

the clean water service sector. Therefore, the quality in the service sector is still lacking and is not relevant to customer demands. This problem needs serious attention from clean water service stakeholders, especially local governments, to provide quality services in the field of clean water services that are relevant to current customer demands without sacrificing customer value reduction in the community. Emotional value, social, performance and price are hot issues in the field of clean water services today. These issues are prospective to be developed in service as a strategy to capture excellent service in the clean water service sector to meet customer value

Path	Estimate	S.E	C.R	P
X2 → X3	0.386	0.048	8.045	***
X3 → Y	-.717	0.207	-3.464	***
X2 → Y	1.181	.108	10.897	***

Table 5: Path Analysis

Source: Primary Data Processed, 2020

E. Results of the Discussion

- Service quality significantly and positively affects customer value. However, the quality in the PDAM service sector must be improved and relevant to the demands of customers and must continue to maintain service quality and service values in interactions with customers to achieve the company's desire to be sustainable. Advances in Information Technology have had a significant effect on the drinking / clean water sector and have triggered changes both on the demand side of customers (installation of new pipes in homes and businesses) and the supply side (the large number of clean / drinking water orders). Empirically or in fact some of the customers want the pipe installation to be done by PDAM officers. Therefore this study tries to examine the development of drinking / clean water in a number of PDAM customers.
- Customer value plays an important role in the drinking / clean water sector of customers who have value in recommending others to remain PDAM customers as well as to increase new customers which ultimately has the potential to increase customer satisfaction. Customer value is one measure of organizational success. Vanessa (2007: 36), The profit in principle sees the benefits felt by customers / consumers in experiencing the products produced by the company through physical attributes, service attributes and supporting techniques in producing products and the benefits received by customers / consumers, namely the products produced by the company are able to answer all the needs and desires of the customers / consumers.
- Customer satisfaction is influenced by several aspects, in this study the two aspects are service quality and customer value. Clean / drinking water customers are independent of service quality and have multiple effects on the objective of supporting excellent service, for example in the aspects

of service tangibles (direct evidence), competence (competence), reliability (responsiveness) and courtesy (courtesy).

VI. CONCLUSION

Based on the analysis, it can be concluded that there is a significant direct influence between service quality and customer value where the regression weight coefficient is marked positive, indicating that the higher the diversification of clean water products will increase the customer value. And the reduced level of customer value will reduce lower customer satisfaction. This shows that customer value has a mediating effect on service quality on customer satisfaction. Based on the results of the research it is clearly suggested that: to increase customer satisfaction, quality in service is needed and strive to get maximum customer value.

REFERENCES

- [1]. Agyapong, G. K. Q. 2011. The Effect of Service Quality on Customer Satisfaction in the Utility Industry – A Case of Vodafone (Ghana). *International Journal of Business and Management*, 6(5), 203-210.
- [2]. Badan Litbang Departemen Pekerjaan Umum. (2005). *Penyediaan Air Minum Berbasis Masyarakat (PAM BM)* Jakarta: Litbang Departemen Pekerjaan Umum.
- [3]. Bappenas. (2003). *Kebijakan Nasional Pembangunan Air Minum dan Penyehatan Lingkungan Berbasis Masyarakat*. Jakarta: Deputi Bidang Sarana dan Prasarana Badan Perencanaan Pembangunan Nasional.
- [4]. Chi, Christine G. & Gursoy, Dogan. 2009. Employee Satisfaction, Customer Satisfaction, and Financial Performance: An Empirical Examination. *International Journal of Hospitality Management*, 28(2), 245-253.



- [5]. Dodds, William, B., Kent, B. Monroe, & Grewal, Dhruv. 1991. Effects of Price, Brand, and Store Information on Buyers Product Evaluations. *Journal of Marketing Research*, 28, 307-319.
- [6]. Dukic, S. & Kijevcanin, V. 2012. Service Quality as Determinant of Customer Satisfaction. *Review paper Economics and Organization*, 9(3), 311-325.
- [7]. Gallarza, M. G., Gil-Saura, I. & Holbrook, M. B. 2011. The Value of Value: Further Excursions on The Meaning and Role of Customer Value. *Journal of Consumer Behaviour*, 10(4), 179-191.
- [8]. Giese, J. L. & Cote, J. A. 2000. Defining Customer Satisfaction. *Academy of Science Review*, Vol. 2000 No. 1.
- [9]. Gunderson, M. G., Heide, M. & Olsson, U. H. 1996. *Hotel Satisfaction Among Bussiness Travellers*. Cornell H. R. A.
- [10]. Gursoy, Dogan & Swanger, Nancy. 2007. Performance-Enhancing Internal Strategic Factors And Competencies: Impacts On Financial Success. *Hospitality Management*, 26, 213–227.
- [11]. Hamburg, C., W. D.Hoyer and Fassnacht.M. (2006). Service Orientation of a Reteiler's. University of Hamburg, P. E. Mc-Culloch. Germany
- [12]. Keith, D. & Newstrom, J. W. 1995. *Perilaku Dalam Organisasi*. Edisi Ketujuh. Jakarta: Erlangga.
- [13]. Kotler, P. & Keller, K. L. 2012. *Marketing Management*. 14<sup>th</sup>Edition. New Jersey: Prentice-Hall Published.
- [14]. Kuo, Ying-Feng., Wu, Chi-Ming & Deng, Wei-Jaw. 2009. The Relationship Among Service Quality, Perceived Value, Customer Satisfaction, and Post-Purchase Intention in Mobile Value-Added Services. *Journal of Computers in Human Behavior*, 25(4), 887-896.
- [15]. Lam, Shun Y., Shankar, V., Erramilli, M. K. & Murthy, B. 2009. Customer Value, Satisfaction, Loyalty, and Switching Costs: An Illustration From a Business-to-Business Service Context. *Journal of The Academy of Marketing Science*, 32(3), 293-311.
- [16]. Lawang, R. MZ. 2005. *Kapital Sosial dalam Perspektif Sosiologi: Suatu Pengantar*. Jakarta: Fisip-UI.
- [17]. Malhotra, Naresh. 1993. *Riset Pemasaran, Manajemen Pemasaran Riset*. Jakarta: Indeks Kelompok Gramedia.
- [18]. McLeod, R. & Schell, G. P. 2007. *Management Information Systems*. 10<sup>th</sup>Edition. New Jersey: Pearson Education.
- [19]. Mohan, G., & Stokke, K. (2000). Participatory Development and Empowerment: The Dangers of Localism. *Third World Quarterly*, 21, 247-268. <http://dx.doi.org/10.1080/01436590050004346>
- [20]. Norment, T. K., Wardrup, L. C., & Callahan, V. F. (2007). *Performance and Oversight of Virginia's Small Community Drinking Water Systems*. Virginia: This report is available on the JLARC website at <http://jlarc.state.va.us>.
- [21]. Ojo, Olu. 2010. The Relationship Between Service Quality and Customer Satisfaction in the Telecommunication Industry: Evidence From Nigeri. *Broad Research in Accounting, Negotiation and Distribution*, 1(1), 88-100.
- [22]. Oliver, Richard L. 1999. Whence Consumer Loyalty. *Journal of Marketing*, 63(4), 33-44.
- [23]. Soerjono, S. 2007. *Sosiologi Suatu Pengantar*. Jakarta: PT Raja Grafindo Persada.
- [24]. Suryana, 2003. *Kewirausahaan Pedoman Praktis: Kiat dan Proses Menuju Sukses*. Jakarta: Salemba Empat.
- [25]. Sweeney, J. & Soutar, G. 2001. Consumer Perceived Value: The Development of A Multiple Item Scale. *Journal of Retailing*, 77(2), 203-205.
- [26]. Tabachnick, B. G. & Fidell, L. S. 2007. *Using Multivariate Statistics*. 5<sup>th</sup> Edition. California: Pearson Education Inc.
- [27]. Tjiptono, Fandy & Chandra, G. 2005. *Service, Quality & Satisfaction*. Yogyakarta: Andi.
- [28]. Tjiptono, Fandy 2012a. *Manajemen Pemasaran*. Yogyakarta: Andi.
- [29]. ----- . 2012b. *Service Management Mewujudkan Layanan Prima*. Yogyakarta: Andi.
- [30]. Vanessa, G. 2007. *Customer Relationship Management and Marketing Public Relations*. Bandung: Alfabeta.
- [31]. Walker, R. H., Johnson, L. W. & Leonard, S. 2006. Re-Thinking The Conceptualization of Customer Value and Service Quality Within The Service-Profit Chain. *Journal of Service Theory and Practice*, 16(1), 23-36.
- [32]. Woodruff, Robert B. 1997. Customer Value : The Next Source for Competitive Advantage. *Journal of the Academy of Marketing Science*, 25(2), 139 –153.
- [33]. World Health Organization. (1997). *Guidelines for drinking-water quality: volume 3 surveillance and control of community supplies*. Geneva: WHO Library Cataloguing in Publication Data.
- [34]. Yonggui Wang, Y., Lo, Hing-Po & Yang, Y. 2004. An Integrated Framework for Service Quality, Customer Value, Satisfaction: Evidence from China's Telecommunication Industry. *Information Systems Frontiers*, 6(4), 325-340.