

Assessment of Renewable Air-Conditioning Using Economic Feasibility Procedures

Tosin T. Oye*, Keng Goh, Naren Gupta, Toyosi K. Oye
School of Engineering and Built Environment, Edinburgh Napier University,
10 Colinton Rd, Edinburgh EH10 5DT UK

Abstract:- The renewable energy utilization is attaining numerous recognition and diverse assessment is obligatory to be executed for several innovations which has in turn become a general system requirement. The increasing application of fossil fuels is virtually not only triggering swift energy sources depletion; nevertheless, deliberately manufacturing harmful gases which in turn directly impacts humanity. Therefore, this paper addresses the economic assessment of renewable air-conditioning using ARR, NPV, IRR and payback period technique. Knowing the obscured fossil fuels effects and its consequences to human wellbeing is key for assessing renewable-based air-conditioning using economic feasibility practices and for underpinning further remarkable conclusions for imminent energy production. The system economic assessment is measured in conjunction with the use of cleaner energy sources, vis-à-vis renewable energy utilization such as photovoltaic solar power. The outcome reveals that photovoltaic solar air-conditioning is worth undertaking using economic assessment procedures. The accounting rate of return is 185.7%; the net present value yielded a positive value $NPV > 0$ which suggests the project is worth undertaking; payback period is 9.5 years, and this typically demonstrates that the system will begin to make profit after 9.5 years of operation and at the discount rate of up to 10.19%, photovoltaic solar air-conditioning investment is worth undertaking.

Keywords:- Air-conditioning; Renewable energy; Economic assessment; Energy consumption; Carbon emissions; Health effects.

I. INTRODUCTION

Substantial portion of the significant energy utilized in building is signified as cooling or heating. The escalating use of air-conditioning systems permits generating cooling developments which can competently use renewable energy such as the application of solar power for its task. Inconsistencies in the costs of fossil fuel have presented incentive to an energetic pursuit for alternative source of power. Observing the solar power utilization for cold production was manufactured via a French innovator in 1869 which is the inventive solar power origination [1]. Nonetheless, the principal system of solar cooling was

explicitly revealed through alike expert in 1878 during the General Exhibition in Paris [2]. Similarly, ice learners were conveyed through the system with an illustrative reflector and an alkali-water ingestion chiller. Moreover, the succeeding solar cooling demonstrations were sustained till the 1980s. Afterward, the most up-to-date resume of inclusive solar cooling investigation was carried out near the beginning of the 21st century, subsequently the beliefs as to linking photovoltaic and electric-driven chillers were escalated amongst researchers.

Frequently growing requirements of wellbeing in buildings and transportation creates the cooling directive which makes development in the cooling business domain. These comfort fundamentals are encouraging the air-conditioning as a prerequisite in commercial buildings which is not in turn detected as a luxury. Due to these grounds and subsequently for the purpose to diminish the level of energy consumption and carbon emissions, a fast-emerging commercial domain of solar air-conditioning systems can be expected. This has continued unobserved via several policy makers, somewhat on the basis that cooling requirements are regularly being encountered through electrical air conditioners, covering the component of cooling within the building's universal control operation [3]. By 2020, exploration recommended that in the EU an upsurge in the percentage of occupational buildings equipped with cooling systems is dependent on to influence about 60%. The utmost possible cooling demand in Europe should be 100% of the entire room since air-conditioning is typically estimated to be 1400 TWh yearly cooling [4]. However, to quantify the efficiency of assets utilized and to quantify the efficiency of the renewable air-conditioning – the analysis of economic assessment profitability is contemplated as one of the best methods.

Therefore, this paper focus upon the economic assessment of renewable air-conditioning though utilizing profitability procedures. The economic assessment procedures subsequently contribute to the industry and renewable energy studies by presenting the economic assessment outcome of solar-based air-conditioning as a way forward towards embracing a cleaner energy source to lessen the societal level of energy consumption and the rate of CO₂ in the hottest period of the year.

II. RENEWABLE AIR-CONDITIONING

According to [5], the damaging influences of traditional air-conditionings (release of carbon emission and the application of ecologically unfriendly refrigerants) and their high energy usage lead scholars to investigate into more cleaner energy sources, predominantly the solar energy. The innovation of the absorption type of cooling system is the utmost employed in the domain of air-conditioning [6,7,8]. Somewhat than the compressor, the absorption-type exploits an absorber and a generator. Hereafter, to compel the refrigerant (water or alkali), no electrical energy is anticipated [9]. The refrigerant is principally situated for absorbent material and subsequently forced in the used-up fluid stage. The pressurized retaining mixture is then reheated in a solar-regulated producer to recuperate the vapor of pressurized refrigerant. Successively, in the condenser; it is dissolved to stop fluid, which is then increased through an additional nozzle. In the evaporator, the cool refrigerant creates the refrigeration effect. The refrigerant is stimulated at last to the absorber and an alternative sequence is beginning. Hence, absorption-type complement to lessening the costs of power and the emissions of the greenhouse gas to the atmosphere. Moreover, they possess a small coefficient of performance of about 0.75 – 0.3 as specified through the cooling boundary in accordance to the air-conditionings electrical pressure vapor which their coefficient of performance may be in the range of up to three [9]. The solar air-conditioning working guideline is delineated in fig. 1.

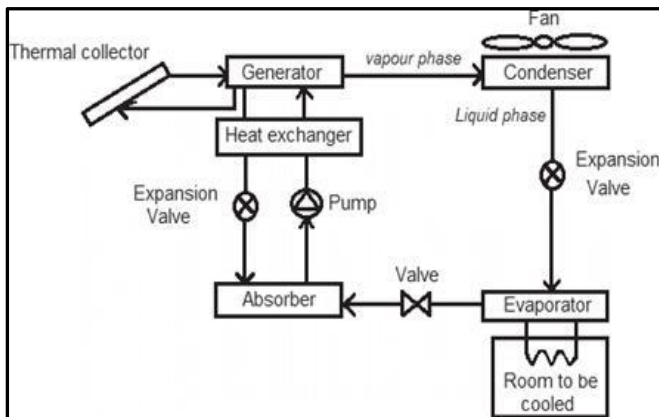

Fig 1:- The solar air-conditioning absorption-based.

Accordingly, the brief strategy presenting the essential parts of the projected cooling system is offered in fig. 2, as specified by [10].

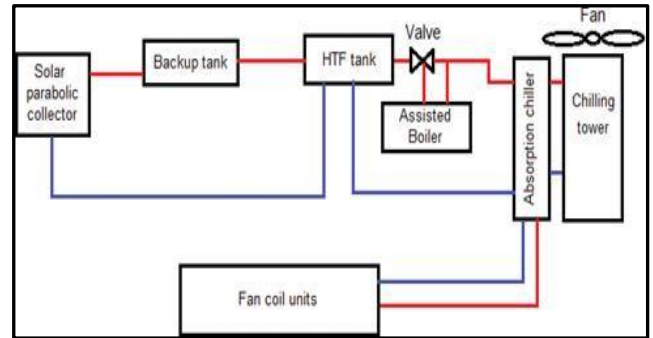

Fig 2:- Solar cooling synoptic representation utilising parabolic accumulators.

In addition, the high surrounding temperatures in Bay countries originate an endless attention for cooling, which in turn allows achieving a remarkable rational expansion in the domain of solar air-conditioning. For instance, the study via [11], intensified on progressing solar-controlled exhibition in Saudi Arabia of LiBr-water absorption air-conditioning. It is equipped with volume containers having refrigerant and cold level plate accumulator, which assure a reliable duty 24 hours in 7 days with 5 kW cooling limit chiller [11]. For its elasticities over-all technical model using delicate estimations time-subordinate of the surrounding temperature and the solar energy that are supposed to be stable with specified small intervals Δt . Also, the addition power calculation of specific Δt , supposes static stream methods is stated by equation (1).

$$Q - W = (\Sigma m \cdot h)_{out} - (\Sigma m \cdot h)_{ix} + m(u_f - u_i)_{system} \tag{1}$$

The Q and W is the power-driven and energies of the net thermal, and $(u_f - u_i)$ is inner power change per unit mass by the time within the volume V . Likewise, m is the mass inside the volume V of discrete system component. Δt (u_i is the primary value, while u_f is the concluding dominant energy of the volume V per unit mass as of the time stage (Δt)). Furthermore, the mass flow rates fundamental equations of the weak and strong refrigerant-compounds absorbent (ws and ss, discretely) intended for lithium bromide-water are stated by equation (2) and (3) respectively [11].

$$\dot{m}_{ss} = \frac{X_{ws}}{X_{ss} - X_{ws}} \cdot \dot{m}_r \tag{2}$$

$$\dot{m}_{ws} = \frac{X_{ss}}{X_{ss} - X_{ws}} \cdot \dot{m}_r \tag{3}$$

Also, X_{ss} and X_{ws} is the foci mass for weak and strong complexes. The pump, evaporator heat, and producer exertion are obtainable in equation (4), (5) and (6) [11].

$$Q_G = (\dot{m}_r h_1 + \dot{m}_{ws} h_8 - m_{ss} h_7) \cdot \Delta t \tag{4}$$

$$Q_E = (\dot{m}_r (h_4 - h_3)) \cdot \Delta t \tag{5}$$

$$Q_P = (\dot{m}_{ss} (h_6 - h_5)) \cdot \Delta t \tag{6}$$

As revealed in fig. 2, enthalpy h (1 to 10) is based on thermodynamic state and Δt is the step interlude of 1-h time [11]. A hot storage mass of 1500 kg is required for a steady load and an accumulator area of 48 m² – outcomes of simulation presented that the system coefficient of performance is about 0.85. Moreover, the investigative results established that it may attain 0.9 [11]. The system segments size degree (accumulator and tanks) subsequently turned out smaller in summer with high solar power. Thus, the coefficient of performance will be upgraded, and the important mass storage will be reduced. Numerous related researches were carried out in Australia in a similar setting. For instance, investigations by [12], established a building with 60 m³ volume equipped with an autonomous air-conditioning having solar photovoltaic battery to achieve the perfect comfort possessing the lowest energy consumption. The air temperature T_s and the habituated humidity ratio HR_s are calculated through equation (7) and (8) [12].

$$T_s = T_b - \frac{Q_s}{m c_p} \tag{7}$$

$$HR_s = HR_b - \frac{Q_t - Q_s}{m h_{fg}} \tag{8}$$

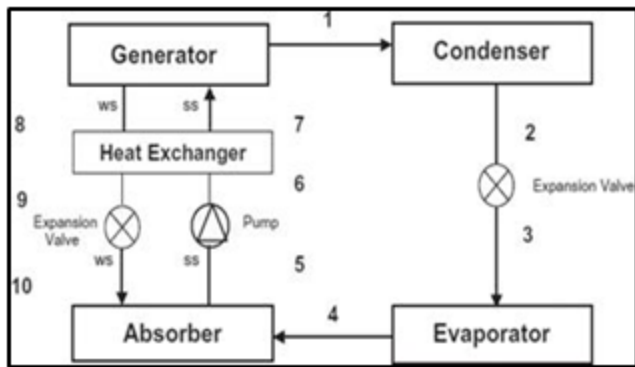

Fig 3:- LiBr-H₂O absorption thermodynamic state.

Consequently, Q_t and Q_s is the entire workable power and cooling, h_{fg} is the water heat evaporation, m is the flow rate of supply air (0.275 kg/s), and T_b is the air-temperature of the building [12]. The battery proximity is mandatory, and the scheme can be applied during acme periods to produce the mandatory power. The reserved power in the battery $E_{battery}$ is determined through equation (9) [12].

$$\frac{dE_{battery}}{dt} = \eta_c P_c - \frac{1}{\eta_d P_d} \tag{9}$$

Likewise, η_c is the efficiency charge, η_d is the efficiency of discharge, P_d is discharging energy battery and P_c is energy battery charging. The regeneration significances of inside temperature and humidity were carried out for numerous categories of buildings and climates by means of TRNSYS programming. Thirty percent of the solar portion the system was improved [12]. Similarly, medium temperature and warm foci solar accumulators are applied in air-conditioning having a double effect auxiliary heater and absorption chiller to cool a building [13]. The important portions of the projected air-

conditioning are seemed in fig. 4 as designated by [13]. For 2.4 m²/kW is the collector territory cooling boundary and 40 L/m² is the capacity tank volume; though applying TRNSYS programming, the simulation outcomes establish that the system can only cover half of the building requirements [13]. Besides, the system coefficient of performance is 1.4 which reveals the proficiency of the system.

Furthermore, study by [14] associates the solar energy to the air-conditioning as habitual vapor pressure to unfold alternative hybrid solar-driven air-conditioning. For the expected system was regulated and exhibited via applying TRNSYS programming in order to advance its productivity of power. It contains three main portions namely; vapor pressure system, solar storage tank and solar accumulator vacuum). The control of the absorber consumption was reduced from 1.45 to 1.24 kW at unflinching state conditions, which is disapproved via a universal saving power of about 7.1% and 14 for only the absorber. Likewise, a saving power that is proficient through the condenser fan is around 2.6% as revealed via [14], which in turn allows an increase in the coefficient of performance. Similarly, the research studies through [14] unfolded that the system can efficiently accomplish the prerequisites cooling.

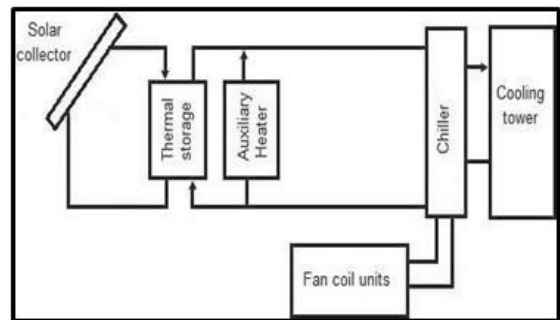

Fig 4:- Solar air-conditioning universal structure components.

III. ECONOMIC ASSESSMENT PROCEDURES

Discretely from the long-term and short-term creditors, management and owners likewise amuse in the reliability of the solar air-conditioning which can perhaps be sustained through economic profitability assessment. Studies unfolded that photovoltaic electric of up to 2.5 kWh/d is sufficient for home-based requirements and as consequence, all components examined is within the aforementioned specification. According to [15], this implies that a 2.5kW solar system will yield *electricity* of about (2.35kWh x 2.5kW) = 5.9kWh per day, averaged through the year. This interprets into power of about 2,140kWh per year. According to [16], the average costs of photovoltaic solar air-conditioning is £3998.62 which includes all the system components and installation cost. Studies by [15] revealed that solar system is becoming cheaper since 2.5kWh system cost about three times the current price of the system in the last twelve months. Nevertheless, the estimated photovoltaic solar air-conditioning average installation costs are employed.

Consequently, the costs of maintenance specified consist of the system adjustment and periodical check. Twenty years is the lifespan of the system components as specified by the manufacturer and the proposed costs of the system average maintenance is £75 per year. The annual feed in-tariff and the export tariff for the photovoltaic system is 14.90p/ unit and 4.64p/ unit respectively while having a guaranteed twenty-year tariff lifetime.

A. Accounting Rate of Return (ARR)

The accounting rate of return research studies commenced by [17,18,19] respectively, and sustained through the studies of [20, 21, 22, 23, 24, 25, 26, 27, 28, 29] and so on. The key purpose was also to study the connection amongst the internal rate of return and the accounting rate of return or perhaps to practice the valuation process of ARR. For the elementary framework was given in both cases through an economic model and the accounting model was subsequently suitable into the context of economic procedures.

The general accepted formula for accounting rate of return is specified in the equation (10) below:

$$ARR = \frac{\text{Average Annual Profit}}{\text{Initial Investment}} \times 100 \quad (10)$$

$$\begin{aligned} &= \frac{\text{Revenue} - \text{Annual Maintenance Cost}}{\text{Average Annual Profit}} \\ \text{Average Annual Profit} &= 7500.00 - 75.00 = 7425.00 \\ \text{ARR}_{20} &= \frac{7500.00}{3998.62} \times 100 \\ &= 185.7\% \end{aligned} \quad (11)$$

The photovoltaic solar air-conditioning initial investment is £3998.62 while its annual maintenance cost is £75.00 and in twenty years of the system operation, the maintenance costs is £1500.00. Also, the photovoltaic solar air-conditioning investment which includes maintenance is £5498.62 in twenty years of operation – the addition of the initial investment and the cost of its maintenance for twenty years. The proposed revenue of the system is £7500.00 (business income from its normal business activities). The average annual profit is £7425.00, and it is subsequently obtained from the subtraction of the yearly cost of the system maintenance from the revenue. The ARR is subsequently obtained by dividing the average annual profit and the system initial investment. As a result, the accounting rate of return is 185.7%.

B. Net Present Value (NPV)

The Net Present Value is elucidated as the dissimilarity amid cost inflows present value and the outflows of cash present value [30]. That is to say, the net present value of a project - normally calculated as the initial

investment time is the project's cash flow present value from activities and disinvestment less the initial investment amount. For instance, by calculating NPV of the project, the flows of cash occurring at numerous emphases in the period are balanced for the estimation time of cash utilizing rate of discount that is the return smallest rate required for the task to be satisfactory. For the projects possessing positive NPV (or with values in any event equal to zero) are satisfactory and projects possessing negative NPV are unsatisfactory. On the off chance that the project is dismissed - it is dismissed on the grounds that cash flows will likewise be negative. NPV is utilized in budging of capital to investigate the project or investment profitability and it is delicate to the dependability of imminent incomes that the investment, undertaking, project or venture will produce. For example, the net present value equates the value of the pound sterling today to the estimation of that equivalent future pound sterling considering returns and inflation.

The formula for the NPV is expressed in the equation (12) below:

$$NPV = \sum \frac{C_i}{(1+r)^n} - \text{Initial Investment} \quad (12)$$

Where C_i is the flow of cash generated per year; r is the inflation rate and n is the number of years. For higher net present values are advantageous and the rule for precise decision is as follows:

- $NPV > 0$, accept project
- $NPV \leq 0$, reject project

Nevertheless, inflation can perhaps upsurge the future revenue of the photovoltaic solar air-conditioning. Then, the feasibility of substitute investments reduces the future revenue value and interests of bank deposit may perhaps be of assistance in that circumstance. The proposed yearly inflation rate applied in this study is four percent (4%) with the discount rate of five percent (5%). Moreover, to obtain the initial income generated, the average yearly power of the proposed 2.5kW solar system must be multiplied with the feed in-tariff and the export tariff respectively and subsequently added together. Hence, this can be calculated as follows:

$$\begin{aligned} \text{Annual Income} &= (0.149 \times 2140) + (0.0464 \times 2140) \\ &= \pounds 418.16 \end{aligned} \quad (13)$$

As a result, Table 1 revealed the operating profit, generated income and cash flows for the next twenty years of the system.

Annual	Initial Investment	Income	Annual Maintenance Cost	Operating Profit	Cash Flow
Year 0	- £3998.62	-	-	-	-
Year 1	-	418.16	75.00	343.16	343.16
Year 2	-	434.89	75.00	359.89	359.89
Year 3	-	452.23	75.00	377.23	377.28
Year 4	-	470.32	75.00	395.32	395.37
Year 5	-	489.13	75.00	414.13	414.19
Year 6	-	508.70	75.00	433.70	433.76
Year 7	-	529.05	75.00	454.05	454.11
Year 8	-	550.21	75.00	475.21	475.27
Year 9	-	572.22	75.00	497.22	497.28
Year 10	-	595.11	75.00	520.11	520.17
Year 11	-	618.91	75.00	543.91	543.98
Year 12	-	643.67	75.00	568.67	568.74
Year 13	-	669.42	75.00	594.42	594.49
Year 14	-	696.20	75.00	621.20	621.27
Year 15	-	724.05	75.00	649.05	649.12
Year 16	-	753.01	75.00	678.01	678.08
Year 17	-	783.13	75.00	708.13	708.21
Year 18	-	814.46	75.00	739.46	739.53
Year 19	-	847.04	75.00	772.04	772.12
Year 20	-	880.92	75.00	805.92	806.00

Table 1:- The system annual income, operating profit and cash flows.

Likewise, the NPV equation (12) can further be expressed as:

$$\frac{C_i}{(1.05)^1} + \frac{1.04C_i}{(1.05)^2} + \frac{1.04C_2}{(1.05)^3} + \frac{1.04C_3}{(1.05)^4} + \frac{1.04C_4}{(1.05)^5} + \dots + \frac{1.04C_n}{(1.05)^n} \quad (14)$$

To obtain the NPV of the solar air-conditioning system, it is essential to substitute the yearly cash flow presented in Table 1 into equation (14). Therefore, the twenty-year net present value with discount of rate 5% (0.05) can be expressed as follows:

$$NPV = 6347.20 - 3998.62 = £2348.58$$

It is feasibly observed that the proposed project yielded a positive value $NPV > 0$ which suggests the project is worth undertaking.

C. Payback Period

Payback period is considered as the required time to recuperate the fundamental interest in a venture from operations. Technique of the payback period for cash correlated investigation is applied to evaluate capital undertakings and to ascertain the yield each year from the beginning of the task pending the aggregated revenues are equal to the expense of the venture at which time the speculation is pronounced to be repaid and the time

engaged to achieve this payback is referred to the payback period [29, 31].

Since the proposed project possesses uneven cash flows, the formula employed for the payback period can be expressed in equation (15) as:

$$\text{Payback Period} = \frac{\text{Initial Investment}}{\text{Periodic Cash Flow}} \quad (15)$$

As a result of an uneven cash flow and to determine how much time to recover the original investment, the payback period can further be expressed as:

$$\text{Payback} = \frac{\text{Years before full recovery}}{\text{Unrecovered cost at start of the year}} + \frac{\text{Cash flow during the year}}{\text{Cash flow during the year}} \quad (16)$$

Furthermore, year 9 (nine) is the year before the initial investment is completely recovered; however, to calculate the unrecovered cost at start of the year, the initial investment must be subtracted from the addition of the cash flows by the end of the 9th year. Furthermore, the cash flow throughout the year is the flow of cash when the project has fully recovered from its initial investment.

$$\begin{aligned} & \text{Unrecovered cost at start of the year} \\ & = \text{Initial Investment} \\ & - \text{Cash flows by the end of year 9} \end{aligned} \quad (17)$$

Subsequently, the payback period is expressed and calculated as follows:

$$\text{Payback} = 9 + \frac{248.31}{520.17} \quad (18)$$

Payback period = 9.5 years

The estimated payback period is 9.5 years, and this typically demonstrates that the system will begin to make profit after 9.5 years of operation.

D. Internal Rate of Return (IRR)

The IRR appears to be the rate of discount frequently applied in budgeting of capital that forms all cash flows net present value from a particular venture equal to zero. This predominantly infers that internal rate of return is subsequently the rate of return that forms the whole imminent cash flows present value and the project last market value equivalents to the value of present market [32, 33, 34]. The higher an investment IRR, the further alluring it is to accept the venture [34]. Therefore, it is utilized to rank numerous potential ventures or systems an organization or individual is contemplating. Thusly, the internal rate of return provides a straightforward impediment, through which any project should stayed away from if the capital expense exceeds this rate. Internal rate of return is additionally alluded to as economic rate of return. A straightforward criterion of making decision can perhaps be to acknowledge a task if its IRR surpasses the expense of capital and dismissed if the internal rate of return is not exactly the capital cost.

In this paper, the internal rate of return is calculated through IRRCalculator.net software program as research studies revealed that internal rate of return cannot be calculated analytically; and must as an alternative be calculated by utilizing software programs like Excel or trial-and-error technique. As a result, the internal rate of return for the economic assessment of the proposed system is 10.19%. That is to say, the assessment outcome demonstrates that at the discount rate of up to 10.19%, photovoltaic solar air-conditioning investment is worth undertaking.

IV. CONCLUSION

The economic assessment procedures demonstrate how significant savings can perhaps be achieved through utilizing a sustainable and renewable means of technology - the photovoltaic solar air-conditioning technology. Each financial assessment indicators depicted that the project is worth undertaking. Therefore, the photovoltaic solar air-conditioning demonstrated to reduce the level of energy consumption and carbon emissions and also saves investment costs. Albeit, over a long period of time, all project ought to earn profits that is sufficient to grow and survive. For improved living standard and national income is the index to the system economic progress. Indubitably,

profit is perhaps the legitimate object of the renewable air-conditioning; even so, it must not remain fundamentally over-emphasized. Possessors of the proposed system may perhaps attempt to make best use of the project profit considering the society welfare. Therefore, profit is not just the return to possessors; however, it is likewise associated with the interest of the society other sectors. Profit is the measure for arbitrating not only for the economic sustainability, but likewise the social purposes, management and efficiency of the system.

REFERENCES

- [1]. A. Mouchot, "Die Sonnenwärme und ihre industriellen Anwendungen". – Oberbözing, Switzerland: Olythus-Verlag, 1987. – 224 p.
- [2]. A. Mouchot, "La Chaleur solaire et ses applications industrielles". – Paris, France: Gauthier-Villars, 1869. – 260 p.
- [3]. D. Mugnier, "New generation solar cooling & heating systems. Task description and Work plan". - IEA Solar Heating & Cooling Programme, 2013. – 30 p.
- [4]. B. Sanner, R. Kalf, A. Land, K. Mutka, P. Papillon, G. Stryi-Hipp, and W. Weiss, "Common Vision for the Renewable Heating & Cooling sector in Europe". – Brussels, Belgium: Renewable Heating & Cooling, 2011. - 48p.
- [5]. MS. Todorovic and JT. Kim, "In search for sustainable globally cost-effective energy efficient building solar system" - Heat recovery assisted building integrated PV powered heat pump for air-conditioning, water heating and water saving. Energy and Buildings. 2014; 85:346-355.
- [6]. A. Allouhi, T. Kousksou, A. Jamil, P. Bruel, Y. Mourad, and Y. Zeraouli, "Solar driven cooling systems: An updated review. Renewable and Sustainable Energy Reviews". 2015; 44:159-181
- [7]. KK. Jasim and JA. Kadhun, "A comparative study of solar thermal cooling and photovoltaic solar cooling in different Iraqi regions". International Journal of Enhanced Research in Science, Technology & Engineering. 2016; 5:63-72
- [8]. NI. Ibrahim, FA. Al-Sulaiman and FN. Ani, "Solar absorption systems with integrated absorption energy storage—A review". Renewable and Sustainable Energy Reviews Forthcoming. DOI: 10.1016/j.rser.2017.07.005
- [9]. J. Aman, DSK. Ting, and P. Henshaw, "Residential solar air conditioning: Energy and exergy analyses of an ammonia-water". Applied Thermal Engineering. 2014; 52:424-432.
- [10]. M. Balghouthi, MH. Chahbani and A. Guizani, "Investigation of a solar cooling installation in Tunisia". Applied Energy. 2012; 98:138-148.
- [11]. MAI. El-Shaarawi and AA. Al-Ugla, "Unsteady analysis for solar-powered hybrid storage LiBr-water absorption air-conditioning". Solar Energy. 2017; 144:556-568
- [12]. MJ. Goldsworthy "Building thermal design for solar photovoltaic air-conditioning in Australian climates". Energy and Buildings. 2017; 135:176-186.

- [13]. Q. Li, C. Zheng, A. Shirazi, OB. Mousa, F. Moscia, JA. Scott and RA. Taylor, "Design and analysis of a medium-temperature, concentrated solar thermal collector for air-conditioning applications". *Applied Energy*. 2017; 190:1159-1173.
- [14]. QP. Ha, and V. Vakiloroyaya, "Modelling and optimal control of an energy-efficient hybrid solar air conditioning system". *Automation in Construction*. 2015; 49:262-270,
- [15]. Solar Selections, "2.5kWp solar systems: Power output", 2019. Available at: <http://www.solarselections.co.uk/blog/2-5kw-solar-systems-pricing-power-output-in-the-uk>
- [16]. HotSpot Energy, "Solar Air Conditioning and Heating". AC-DC Solar Air Conditioners, 2019. Available at: <https://www.hotspotenergy.com/>
- [17]. G.C. Harcourt, "The Accountant in a Golden Age" *Oxford Economic Papers* (March), 1965: 66-80.
- [18]. E. Solomon, "Return on Investment: The Relation of Book-Yield to True Yield" in R. K. Jaedicke, Y. Ijiri and N. Oswald, eds., *Research in Accounting Measurement* (American Accounting Association): 1966, 232-244.
- [19]. WJ. Vatter, "Income Models, Book Yield and the Rate of Return," *The Accounting Review* (October):1966; 681-698.
- [20]. JA. Kay, "Accountants, Too, Could Be Happy in the Golden Age: The Accountants Rate of Profit and the Internal Rate of Return". *Oxford Economic Papers* (November): 1976; 447-460.
- [21]. JA. Kay, "Accounting Rate of Profit and Internal Rate of Return: A Reply," *Oxford Economic Papers* (May 1978): 469-470.
- [22]. K.V. Peasnell, "Some Formal Connections Between Economic Values and Yields and Accounting Numbers." *Journal of Business Finance & Accounting* (Autumn): 1982; 361-381.
- [23]. JR. Franks, and SD. Hodges, "The Meaning of Accounting Numbers in Target Setting and Performance Measurement: Implications for Managers and Regulators;" *Clean Surplus: A Link Between Accounting and Finance*. New York: Garland Publishing, Inc, 1984.
- [24]. J. Edwards, J. Kay, and C. Mayer, *The Economic Analysis of Accounting Profitability* (Oxford: Clarendon Press 1987).
- [25]. JA. Kay, and CP. Mayer, "On the Application of Accounting Rates of Return". *Economic Journal* (March 1986): 199-207.
- [26]. RP. Brief, and R.A. Lawson, "The Role of the Accounting Rate of Return in Financial Statement Analysis". *The Accounting Review* 67 (April 1992): 411-426.
- [27]. RP. Brief, "Using Accounting Data in Present Value Models," *Journal of Financial Statement Analysis* 1996; 21-29.
- [28]. RP. Brief, "The Accounting Rate of Return as a Framework for Analysis" Leonard N Stern School of Business, New York University, 1999.
- [29]. MK. Al-Ani, "A Strategic Framework to Use Payback Period in Evaluating the Capital Budgeting in Energy and Oil and Gas Sectors in Oman". *International Journal of Economics and Financial Issues*, 2015, 5(2), 469-475.
- [30]. SR. Jory, A. Benamraoui, DR. Boojihawon, and NO. Madichie, "Net Present Value Analysis and the Wealth Creation Process: A Case Illustration". *The Accounting Educators' Journal* Volume XXVI 2016 pp. 85-99.
- [31]. TS. Ong, and CH. Thum, "Net Present Value and Payback Period for Building Integrated Photovoltaic Projects in Malaysia". *International Journal of Academic Research in Business and Social Sciences*. February 2013, Vol. 3, No. 2 ISSN: 2222-6990.
- [32]. Y. Stefan, "Developments of the payback method" *Int. J. Production Economics* 67 (1999) 155 – 167.
- [33]. A. Rangel, J. Santos, and J. Savoia, "Modified Profitability Index and Internal Rate of Return". *Journal of International Business and Economics* December 2016, Vol. 4, No. 2, pp. 13-18 ISSN: 2374-2208.
- [34]. C. Neil, D. Steven, and W. Peter, "The implied internal rate of return in conventional residual valuations of development sites. *Journal of Property Research*. ISSN: 0959-9916 (Print) 2018; 1466-4453.