

Improvement of Production Productivity and Process Capability to Create a Production Process Controlled by Quality and Quantity Case Study on the Production Line Assy Element Assy, Factory 2 Production Area, PT. XYZ

Martin Darmawan, Mislan, Afifulloh, Erry Rimawan
^{1,2} Department of Industrial Engineering,
 Mercu Buana University, Meruya, Jakarta, Indonesia

Abstract:- Good work system design is one of the keys to success of a company. Because at this design stage all the entities in the work system are properly arranged and prepared in order to achieve the targets set by the company. In this study what is meant by company targets is the target in terms of production productivity and targets in terms of process capability Be rhubungan with the quality of products produced. Based on this, the research conducted on the Production Line Assy Element Assy in the Factory 2 Production Area of PT. XYZ aims to improve the competitiveness of companies through the design of good work systems to increase production productivity, and through evaluating the critical processes contained in the work system in order to improve process capabilities that are closely related to the quality of the products produced.

In fact there are two variations of work processes found in the work system of the Production Line Sub Assy Assy in the Production Area of Factory 2, PT. XYZ, namely: Sub Production Process Assy Element Assy (End Plate B Plastisol, and End Plate A Plastisol Product), and Sub Production Process Assy Element Assy (End Plate A Plastisol, and End Plate B Macroplast Product). So that the improvements made include both variations of the work process.

Study methods of working time and line balancing are used in solving process bottle neck problems in the work system. With the problem of bottle neck process resolved in the work system, it is expected that production productivity in the work system can increase, and meet the targets set by the company. Based on the results of the research conducted, there are fish repairs on both work process variations in the Production Line Assy Element Assy.

In the Sub Production Process Assy Element Assy (End Plate B Plastisol, and End Plate A Plastisol) there was an increase in production capacity of 35.86 %, from the initial production capacity of 11187 units / day , to 15 199 units / day , and there were the increase in line efficiency was 26.57 %, which was from the initial efficiency of 55.17 %, to 69.83%. Whereas in the Sub Production Process Assy Element Assy (End Plate A Plastisol, and End Plate B Macroplast) there is an increase in production capacity of 39.44%, which is

from the initial production capacity of 10789 units / day, to 15044 units / day , and there is an increase in line efficiency of 22.05 %, ie from the initial line efficiency of 68.85 %, to 84.03 %. Or in other words, the production capacity under conditions after repairs has been able to meet the production targets set by the company.

While of the capability evaluation process, which is used as a sample in this study is the improvement process Plastisol Adhesive Dispense contained in Sub Production Line Assy Element Assy in Production Area 2 Factory PT. XYZ. From the results of the research conducted, there was an increase in the value of process capability in the Plastisol Dispense Adhesive Process, namely from the initial condition Cpk value of - 0.14, and Cp value of 0.21, Cpk value of 3.33, and Cp value of 3.52 . Based on the results of these studies, it can be seen that after doing the conformation to the Plastisol Dispense Adhesive Process, the process has been able to meet the process capability targets set by the company.

Keywords:- Bill of Materials (BoMs), Production Layout, Products Classification, Operating Process Chart (OPC), Productivity And Line Balancing, and Process Capability.

I. INTRODUCTIONS

A good work system design, before mass production takes place, is one of the keys to the success of a company. Because all potential problems that can occur, can be known in advance before mass production takes place, so that it can eliminate the potential for larger problems that will arise in the future.

The problems referred to in this case include two things, namely in terms of production capacity related to production productivity and process capabilities related to the quality of the products produced. In fact there are two process variations in the Production Line Assy Element Assy in the Factory 2 Production Area PT. XYZ, namely Sub Production Process Assy Element Assy (End Plate B Plastisol, and End Plate A Plastisol Product), and Sub Production Process Assy Element Assy (End Plate A Plastisol, and End Plate B Macroplast Product). So that the focus of the research in this research is the evaluation of

production capacity and capabilities found in the two production sub-lines.

II. LITERATURE REVIEW

2.1. Bill of Materials (BoMs)

Bill of Materials (BoMs) is an arrangement of the components that make up a product, based on the level of the hierarchy or level. BoMs can provide a clear picture of the tour structure for a product at the stages of the work. According to Limbong (2013), Bill of Materials (BoMs) is a list of all materials used in each type of work.

2.2. Production Layout

Production layout is a pattern or layout of facilities, machines, and factory equipment owned by a company. The production output consists of four types, namely: Loutout Process, Product Layout, Group Layout, and Fixed Position Layout . Rengganis (2015) mentions that the design of factory layout as planning and integration of the flow of components of a product to get the most effective and efficient interrelation between operators, equipment, and material transformation processes from the reception section, to the delivery of finished products.

2.3. Process Classification

According to Kashkoush (2015), formation of product families is of great importance for manufacturing systems which rely on commonality and similarity between products for improving efficiency and productivity. Existing techniques for product family formation are based on similarity measures such as components commonality but none of them consider similarity of the product structure which directly affects the assembly system configuration and the sequence of assembly operations. Based on this, then, in addition to the classification needed for product variations, it is also necessary to classify the process variations. Process classification is a grouping of processes product work that has similarity of process sequence. Classification process helpful in facilitating the improvement process in a production process that has a variety of products and processes that s discussion is diverse, because of variations in the various working processes have been mapped into several groups working processes that can represent the whole of the production process.

2.4. Operating Process Chart (OPC)

Operating Process Chart is a tool in the form of a diagram, which is used to describe the sequence of processes from the beginning to the end of the product.

2.5. Productivity and Balancing Line

2.5.1. Productivity

Productivity can be defined as the level of performance of a process in achieving a pre-determined targets. According to Thi Lam (2016), the quality of the production trajectory will be displayed at the level of productivity, track balance index , and effectiveness of the resources used. There are several technical terms related to productivity, namely: Cycle Time, Takt Time, and Production Capacity.

2.5.2. Balancing Line

Dolgui (2017) mentions that the design of assembly lines is an important issue in manufacturing engineering, management and control. The idle time is the most interesting performance index for assembly line design. The classical simple line-balancing problem (SALBP) consists of assigning tasks, necessary for processing a product, to workstations such that the idle time (number of stations, cycle time, cost) is minimized while precedence constraints between tasks are satisfied. Line Balancing is a method used to analyze the balance of production by dividing the load between processes in a balanced manner, so that there is no waiting process (idle), as a result of waiting for the release of a product from the previous process. There are several terms in the line balancing method, including: Work Stations, Idle Time, Balance Time Balance, Work Station Efficiency, Line Efficiency, Smoothest Index.

2.6. Process Capability

Schmidt (2019) mentions that stability reflects the degree to which a process is free of extrinsic sources of variation. Process Capability is a parameter that can describe the ability of a work process in meeting the set targets based on the variability of the process. The results of the Process Capability measurement are expressed in the form of values Cp and Cpk .

III. RESEARCH METHODOLOGY

The methodology research in conducting this research can be seen in the picture below:

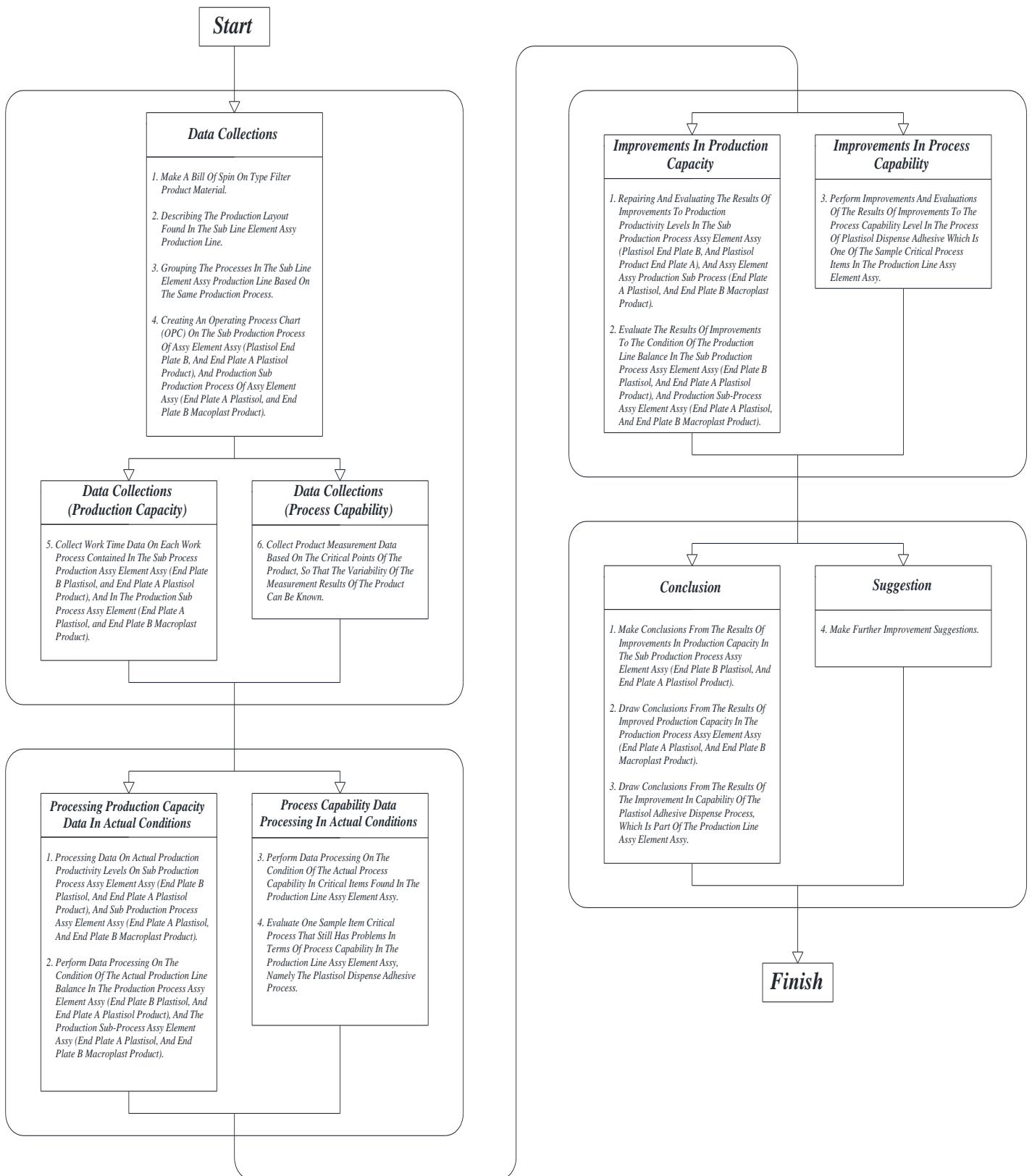

Fig 1:- Research methodology

IV. CASE STUDY

4. 1. Basic Product Knowledge and Bill of Materials (BoMs)

Based on the results of the previous discussion , that which will be used as a sample in this study is in the Production Line Assy Element Assy, with the product in the form of Element Assy. The description of the Element Assy product along with its constituent components can be seen in the following picture:

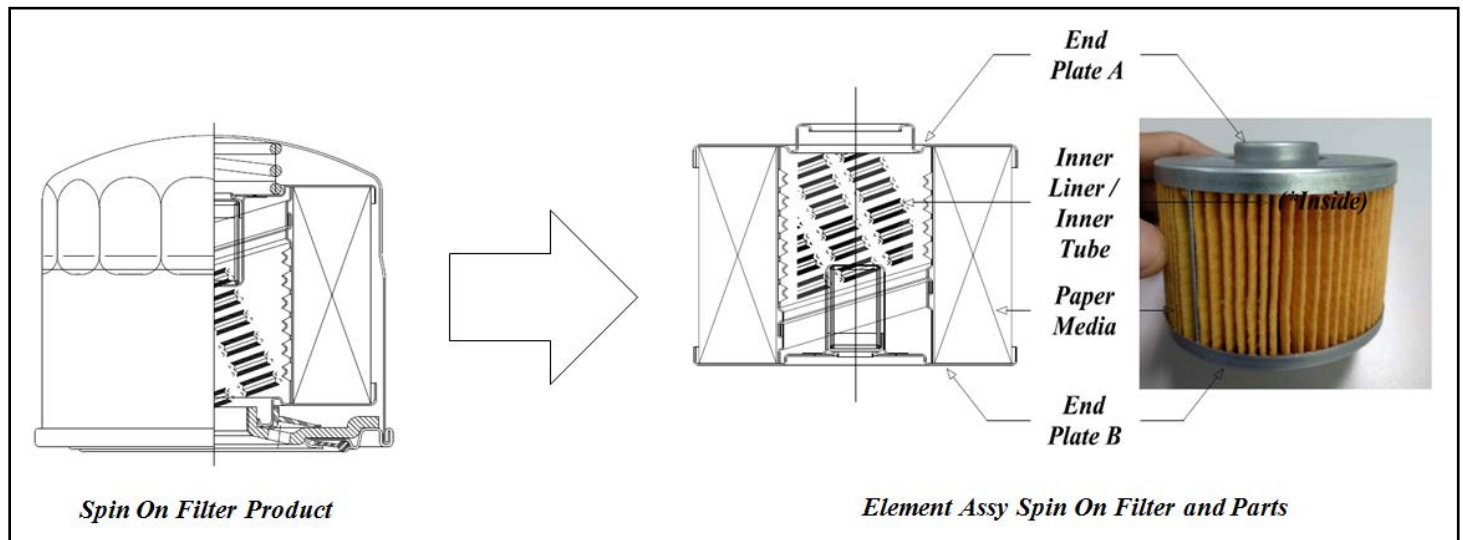

Fig 2:- Element Assy Product and Parts

Process Assy The Product Element Assy is carried out using Adhesive, both the Assy Process on End Plate A, and the End Plate B. Adhesive used in conducting the Assy Process consists of two types, namely: Plastisol Adhesive, and Macroplast Adhesive. Plastisol Adhesive is a type of adhesive that hardens using heat media, which in this case is done by using a Oven Heater. While Adhesive Macroplast is a type of adhesive whose hardening process only requires room temperature within a certain time, because the mixture of this type of adhesive consists of Resin and Hardener.

And here is an arrangement of the components that make up the Spin On Filter Product based on the hierarchy level on Bill of Materials (BoMs) Spin On Filter Products:

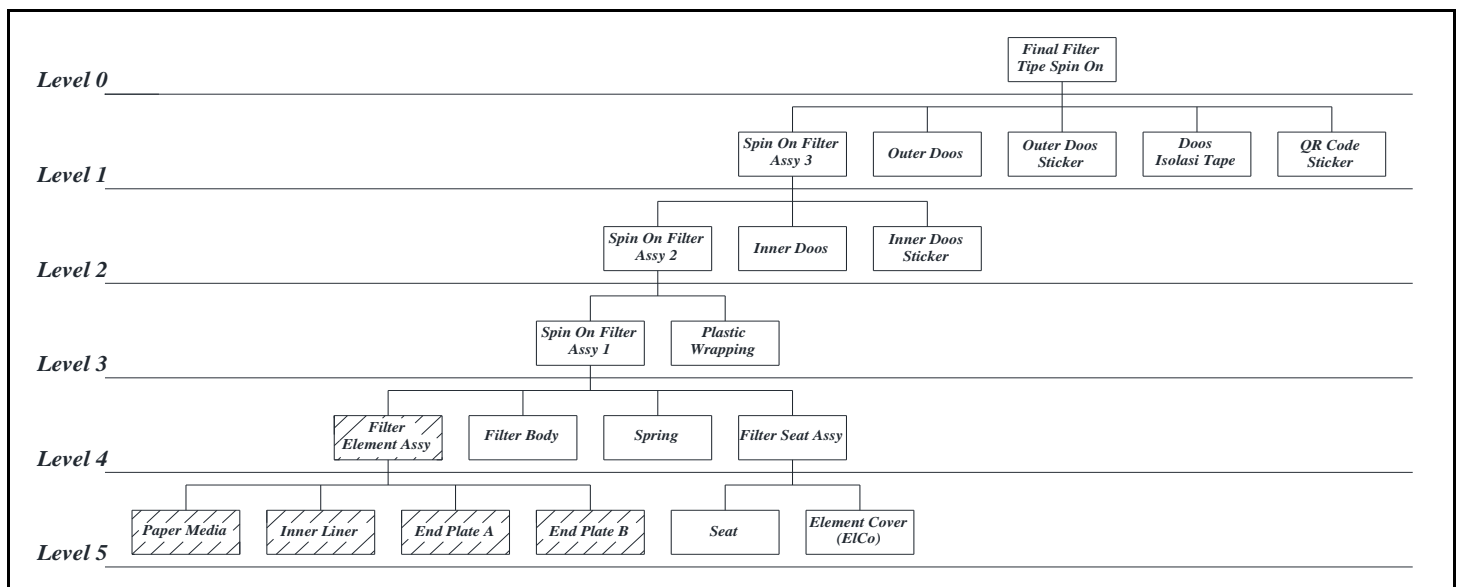

Fig 3:- Bill of Materials (BoMs) Filter Products

Based on product BOMs image filter (Figure 2) above, which will be part of the focus of this study is part of the filter components that are shaded.

4. 2. Production Layout

Production layout found in the Production Line Assy Element Assy in the Factory 2 Production Area PT. XYZ is a production layout in the form of a Process L ayout, with a number of lines of two. The description of the production layout and short flow process on the two Production Line Assy Element Assies can be seen in the picture below:

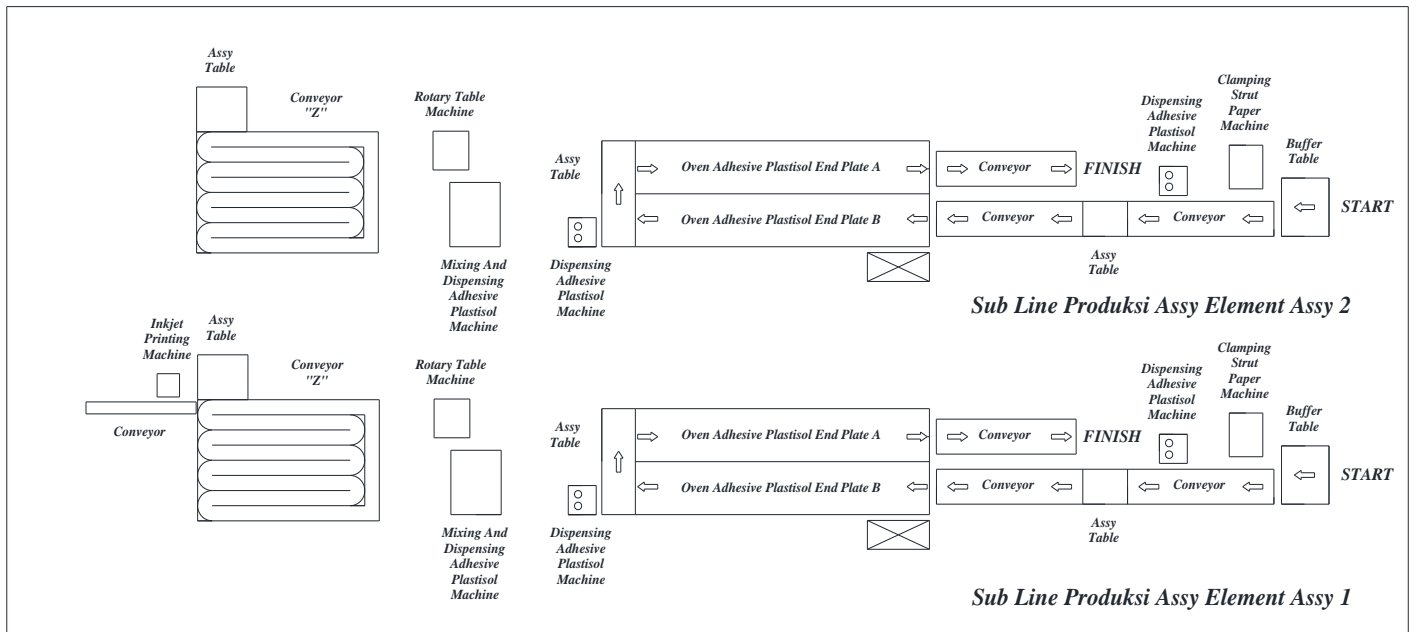

Fig 4:- Production Layout of Sub Production Line Assy Element Assy for Process Assy (End Plate B Plastisol, and End Plate A Plastisol Product)

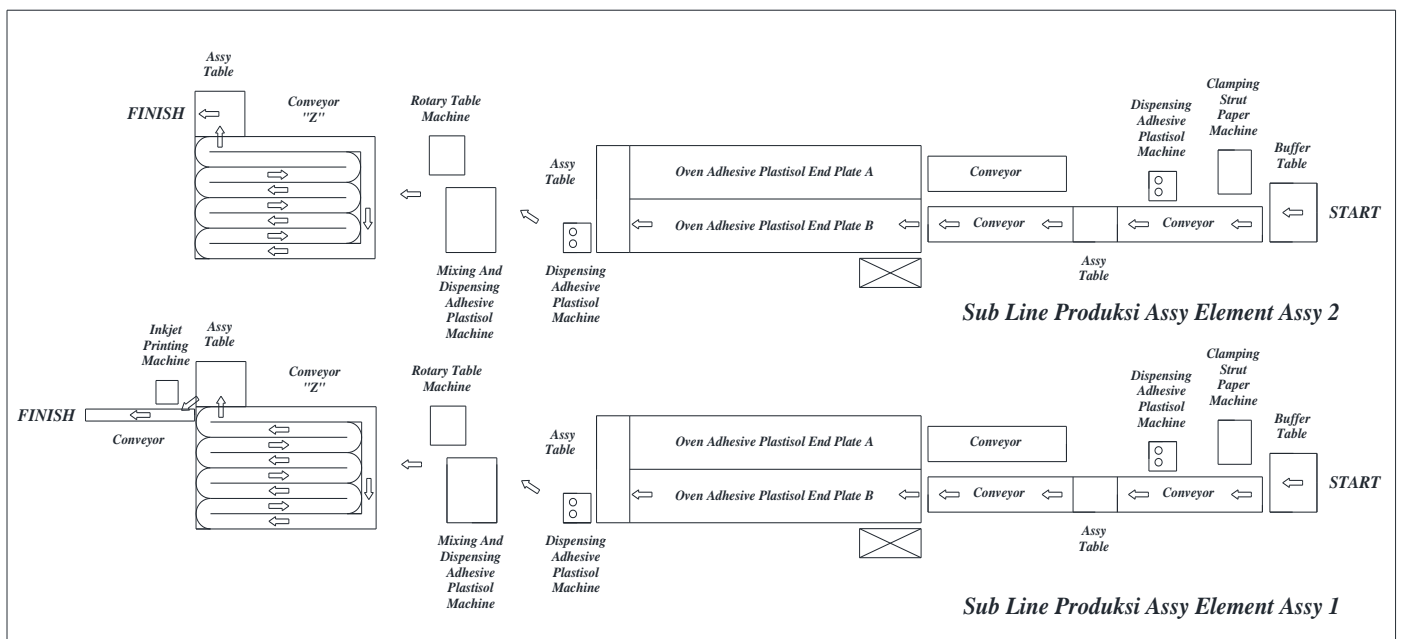

Fig 5:- Production Layout of Sub Production Line Assy Element Assy for Process Assy (End Plate A Plastisol, and End Plate B Macroplast Product)

4. 3. Process Classification

Products manufactured by PT. XYZ is very diverse, so as to facilitate the regulation and improvement of the production process, the work processes based on diverse products are classified into several groups of work processes that can represent the overall variation in the work process. The process classification in the Production Line Assy Element Assy PT. XYZ can be seen in the table below:

Sub-Line Production Code	Sub-Production Line	Code Number Production Sub-Process	Production Sub-Process	Information	Filter Type Category						
					Product Filter Type A	Product Filter Type B	Product Filter Type C	Product Filter Type D	Product Filter Type E	Product Filter Type F	Product Filter Type G
B	Sub-Line Production Assy Element Assy	B-1	Production Sub-Process Assy Element Assy (End Plate B Plastisol, And End Plate A Plastisol Product)	Regular Filter	√	√	√	√	√	X	X
		B-2	Production Sub-Process Assy Element Assy (End Plate A Macroplast, And End Plate B Macroplast Product)	Non Media Paper and End Plate Plastic	X	X	X	√	X	X	X
		B-3	Production Sub-Process Assy Element Assy (End Plate B Plastisol, And End Plate A Macroplast Product)	Using a Tube Pipe on the End Plate A	√	X	X	√	X	X	X
		B-4	Production Sub-Process Assy Element Assy (End Plate A Plastisol, And End Plate B Macroplast Product)	Filter Type B and Type C	X	√	√	X	X	X	X
		B-5	Sub-Production Process Assy Element Assy (End Plate B Plastisol, And Element Cover (ElCo) Macroplast Product)	Type F Flers (Black Tube)	X	X	X	X	X	√	X
		B-6	Production Sub-Process Assy Element Assy (Plastisol End Plate B, Plastic Macroplast Tube, and Macroplast Product Cover Element)	Type F Filter (White Tube)	X	X	X	X	X	√	X

Table 1:- Grouping Process Element Assy Variations at PT. XYZ

And as for the variation of the work process Sub Production Assy Element Assy found in Production Area 2 PT. XYZ , is a yellow shaded part in Table 1 above, namely : Group "B-1", namely: Sub Process Production of Ass y Element Assy (Plastisol End Plate B , and Plastisol Product End Plate A) and "B-4" Group , namely Sub Production Process Assy Element Assy (End Plate A Plastisol, and End Plate B Macroplast Product) .

4. 4. Operating Process Chart (OPC)

The Operating Process Chart (OPC) for the two production process sub-processes can be seen in the picture below:

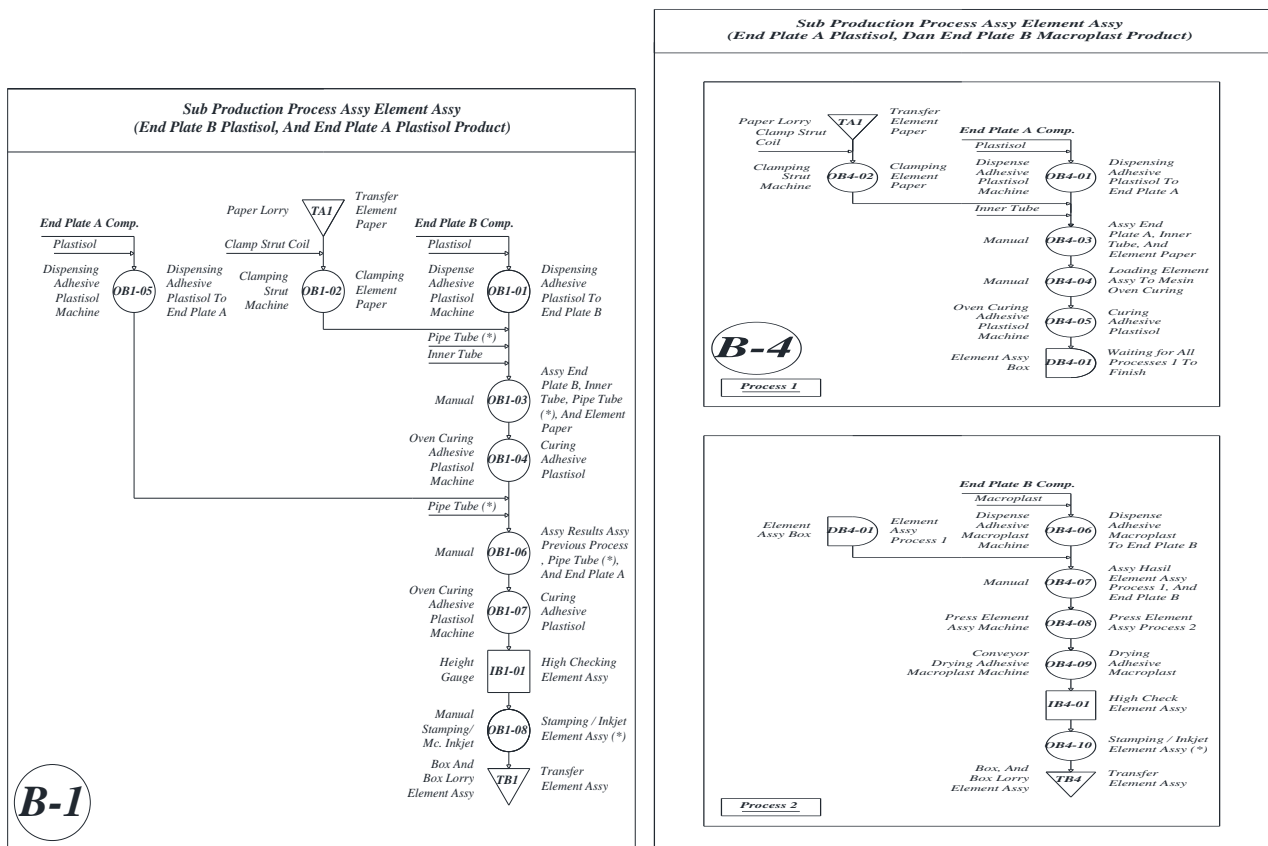

Fig 6:- Operating Process Chart (OPC) Group "B-1", namely Sub Process Production of Assy Element Assy (End Plate B Plastisol, and End Plate A Plastisol Product), and Group "B-4", namely Sub Process Production Assy Element Assy (End Plate A Plastisol, and End Plate B Macroplast Product

4. 5. Actual Production Productivity

The following is a brief general information about the actual conditions of the production system found in the Production Line Assy Element Assy, Factory 2 Production Area, PT. XYZ:

- a. Number of Production Lines = 2 Production Lines,
- b. Work Shift = 2 Shifts, with configuration: 2 Production Line operates in Shift 1, and 1 Production Line operates in Shift 2,
- c. Working Hours = 8 Hours / Shift
- d. Sample Part Number of Filter Products in Sub Production Process Assy Element Assy (End Plate B Plastisol, and End Plate A Plastisol Product) = Part Number "X"
- e. Sample Part Number Filter Products in the Production Sub-Process Assy Element Assy (End Plate A Plastisol, and End Plate B Macroplast Product) = Part Number "Y".

4. 5. 1. Actual Production Productivity Sub Production Process Assy Element Assy (End Plate B Plastisol, and End Plate A Plastisol Product)

From the data processing that is done, then the calculation results obtained to productivity Production in Sub Process Production Element Assy Assy (End Plate B Plastisol and Plastisol Product End Plate A) actual are as follows:

No.	Item	Time	
A. Resume Working Time Measurement Results			
1	Set Up Time (Initial Production)	= 4471.38 ≈ 74.52	Seconds Minute
2	Change Over Time (COT)	= 313.74 ≈ 5.23	Seconds Minute
3	Cycle Time (CT)	= 6.44	Seconds / Pcs
B. Production Target			
4	Production Target	= 300000 ≈ 15000 ≈ 7500	Pcs / Month Pcs / Day (20 Business Days) Pcs / Shift
C. Normal Working Time			
5	Normal Working Time (8 Hours)	= 8 ≈ 480 ≈ 28800	Hour / Shift Minute / Shift Seconds / Shift
D. Takt Time Production			
6	Takt Time Production	= 4.80	Seconds / Pcs (3 Line Prod.) (2 Line Prod. In Shift 1, and 1 Line Prod. In Shift 2)
E. Change Over Time (COT)			
7	Number of Part Number Per Line Per Shift	= 2	Item / Line / Shift
8	COT Time Per Line Per Shift (2 Item / Line / Shift = 1 COT Time)	= 313.74	Seconds / Line / Shift
F. Number of Production Lines			
9	Number of Production Lines	= 3	Production Line / Day (2 Line Prod. In Shift 1, and 1 Line Prod. In Shift 2)
G. Effective Working Time			
10	Effective Work Time	= 24014.88 ≈ 400.25 ≈ 6.67	Seconds / Shift Minute / Shift Hour / Shift
H. Actual Production Capacity			
11	Actual Production Capacity	= 3729	Pcs / Line / Shift
I. Actual Production Capacity VS target Produ c			
	Actual Production Capacity	= 11187	Pcs / Day (3 Line Prod.)
	Production Target	= 15000	Pcs / Day
	Prod Capacity Difference Thp Target Target.	= -3812.94	Pcs / Day

Table 2:- Results of Calculation of Production Productivity Levels in Sub Production Process Assy Element Assy (End Plate B Plastisol, and End Plate A Plastisol Product) Actual

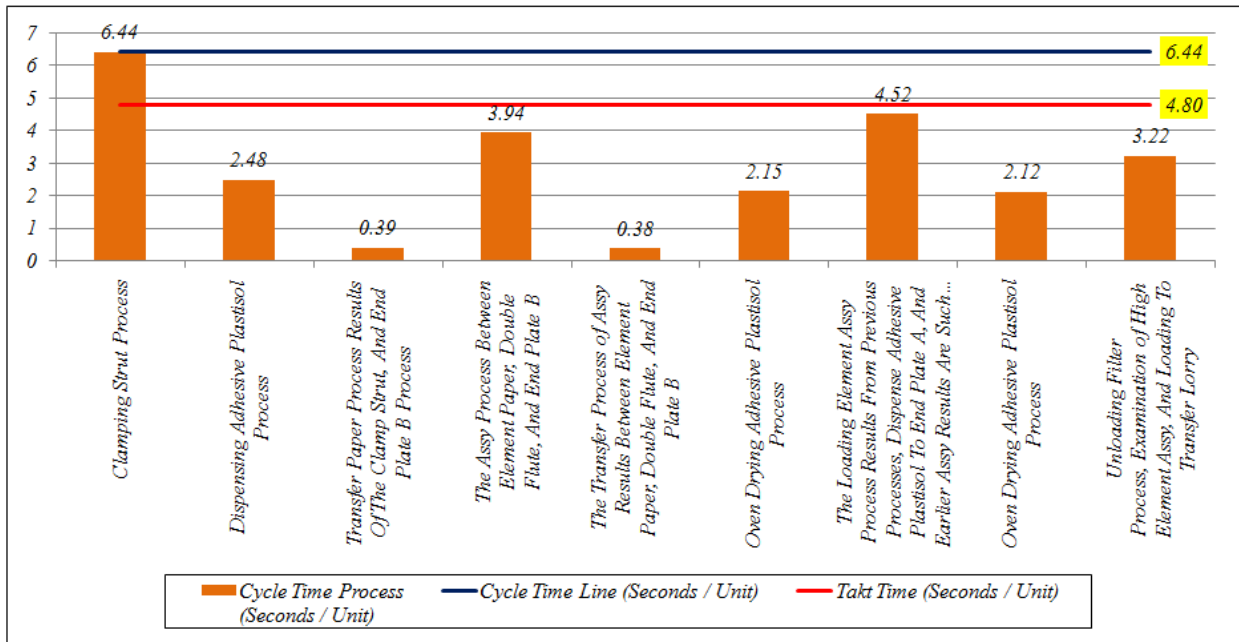

Fig 7:- Distribution of Operating Weight on Sub Process Production Assy Element Assy (End Plate B Plastisol, and End Plate A Plastisol Product) Actual

From the calculations in Table 2, and the graph in Figure 7, it can be seen that there are problems in the Production Process Assy Element Assy (End Plate B Plastisol, and Plastisol End Plate A Products) . This can be seen in the presence of work processes that exceed the Takte of production, namely the Working Process Clamping Strut Paper. And as for the resume level of productivity in the Sub Production Process Assy Element Assy (End Plate B Plastisol, and End Plate A Plastisol Products) can be seen in the table below:

No.	Item	Data Processing Results	
1	Takt Time Process	4.80	Seconds / Pcs (3 Line of Production / Day)
2	Cycle Time Process	6.44	Seconds / Pcs
3	Production Target	15000	Pcs / Day (20 Business Days)
4	Production capacity	11187	Pcs / Day (3 Line of Production / Day)
5	Difference in Production Capacity Against Production Targets	-3813	Pcs / Day

Table 3:- Comparison of Level of Productivity To Resume Production Target on Production Process Assy Element Sub Assy (End Plate B Plastisol and Plastisol Product End Plate A) Actual.

From Table 3, it can be seen that Actual Production Capacity has not been able to meet the Production Targets set by the Company.

4. 5. 2 . Actual Production Productivity Sub Production Process Assy Element Assy (End Plate A Plastisol, and End Plate B Macroplast Product)

From the results of data processing that has been done , then the calculation results obtained for P productivity productivity in the Sub Process Production Assy Element Assy (Actual End Plate A Plastisol, and End Plate B Macroplast Product) are as follows:

No.	Item	Time	
A. Resume Working Time Measurement Results			
1	Set Up Time (Initial Production)	= 5219.08	Seconds
		≈ 86.98	Minute
2	Change Over Time (COT)	= 312.87	Seconds
		≈ 5.21	Minute
3	Cycle Time (CT)	= 6.47	Seconds / Pcs
B. Production Target			
4	Production Target	= 300000	Pcs / Month
		≈ 15000	Pcs / Day (20 Business Days)
		≈ 7500	Pcs / Shift
C. Normal Working Time			
5	Normal Working Time (8 Hours)	= 8	Ja m / Shift
		≈ 480	Minute / Shift
		≈ 28800	Seconds / Shift
D. Takt Time Production			
6	Takt Time Production	= 4.65	Seconds / Pcs (3 Line Prod.) (2 Line Prod. In Shift 1, and 1 Line Prod. In Shift 2)
E. Change Over Time (COT)			
7	Number of Part Number Per Line Per Shift	= 2	Item / Line / Shift
8	COT Time Per Line Per Shift (2 Item / Line / Shift = 1 COT Time)	= 312.87	Seconds / Line / Shift
F. Number of Production Lines			
9	Number of Production Lines	= 3	Production Line / Day (2 Line Prod in Shift 1, and 1 Line Prod. In Shift 2)
G. Effective Working Time			
10	Effective Work Time	= 23268.05	Seconds / Shift
		≈ 387.80	Minute / Shift
		≈ 6.46	Hour / Shift
H. Actual Production Capacity			
11	Actual Production Capacity	= 3596	Pcs / Line / Shift
I. Actual Production Capacity VS target Produ c			
	Actual Production Capacity	= 10789	Pcs / Day (3 Line Prod.)
	Production Target	= 15000	Pcs / Day
	Prod Capacity Difference Thp Target Target.	= -4211.11	Pcs / Day

Table 4:- Productivity Level Calculation Results Production in the Production Sub-Process Assy Element Assy (End Plate A Plastisol, and End Plate B Macroplast Product) Actual

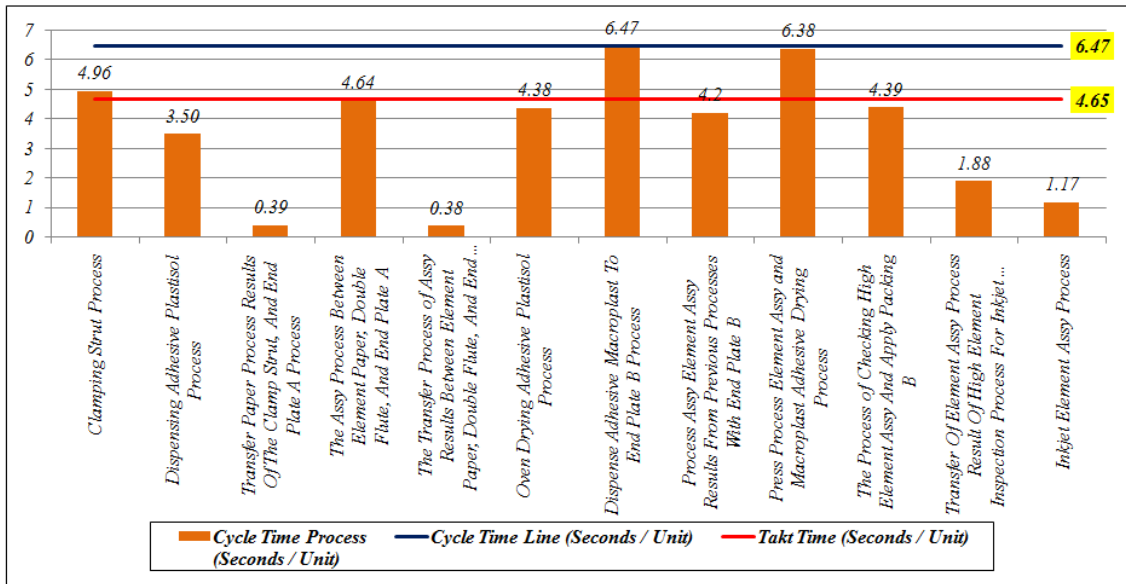

Fig 8:- Distribution of Operating Weight in Sub Process Production of Assy Element Assy (End Plate A Plastisol, and End Plate B Macroplast Product) Actual

From the results of processing the data contained in Table 4, and Figure 8 , it can be seen also that there are problems there are Sub Production Process Assy Element Assy (End Plate A Plastisol, and End Plate B Macroplast Product) . The problem lies in the three work processes contained in the production sub-process, namely: Clamping Strut Process, Macroplast Dispense Adhesive Process to End Plate B, and Press Process Element Assy and Macroplast Adhesive Drying Process . And as for the resume of the level of productivity in the Sub Production Process Assy Element Assy (End Plate A Plastisol, and End Plate B Macroplast Products) can be seen in the table below:

No.	Item	Data Processing Results	
1	Takt Time Process	4.65	Seconds / Pcs (3 Production Lines / Day)
2	Cycle Time Process	6.47	Seconds / Pcs
3	Production Target	15000	Pcs / Day (20 Business Days)
4	Production capacity	10789	Pcs / Day (3 Production Lines / Day)
5	Difference in Production Capacity Against Production Targets	-4211	Pcs / Day

Table 5:- Resume Comparison of Productivity Levels to Production Targets in the Production Sub-Process Assy Element Assy (End Plate A Plastisol, and End Plate B Macroplast Product) Actual

From Table 5, it can be seen that Actual Production Capacity has not been able to meet the Production Targets set by the Company.

4.6. Actual Line Balance Efficiency Process

4.6.1 . Line Balance Efficiency Process in Sub Production Process Assy Element Assy (End Plate B Plastisol, and End Plate A Plastisol Product)

From the collection of data that has been done it can be seen resentful umnya Work B Eban Each P roses in Sub Line Produk i Assy Element Assy (End Plate B Plastisol and Plastisol Product End Plate A) is. And as for the division of expenses K Gov Each P roses on the actual condition can be seen in the following table:

No.	Work process	Operation Time	Idle Time	Station Efficiency
1	Process of Strut Clamping	6.44	0	100.00%
2	Plastisol Dispense Adhesive Process	2.48	3.96	38.51%
3	The Assy Process Between Element Paper, Double Flute, and End Plate A	3.94	2.5	61.18%
4	Process of Plastisol Oven Drying Adhesive	2.15	4.29	33.39%
5	The Loading Element Assy Process Results From Previous Processes, Plastisol To End Plate Dispense Adhesive, And Earlier Assy Results Are Such As Tube Pipes (*), And End Plate A.	4.52	1.92	70.19%
6	Process of Plastisol Oven Drying Adhesive	2.12	4.32	32.92%
7	Unloading Filter Process, Examination of High Element Assy, and Loading To Lori Transfer	3.22	3.22	50.00%
Total		24.87	20.21	

Table 6:- Distribution of Work Load in Sub Process Production of Assy Element Assy (End Plate B Plastisol, and End Plate A Plastisol Product) Actual

And as for the calculation results on Line Balance Efficiency in the production process sub- process can be seen in the table below:

No.	Item	Measurement results
1	Idle Time	20.21 Seconds
2	Line Efficiency	55.17%
3	Balance Delay	44.83%
4	Smoothing Index	8.55

Table 7:- Resume Line Balance Efficiency in Sub Process Production Assy Element Assy (End Plate B Plastisol, and End Plate A Plastisol Product)

From Table 7 it can be seen that the Line Balance Efficiency level in the Sub Process Production of Assy Element Assy (End Plate B Plastisol, and End Plate A Plastisol Product) is still very low. From the table we can know also that the low level of Line Balance Efficiency in Production Sub Assy P roses that, due to the process of K Gov who has time S iklus greater than the Takt Time Production, ie the process Strut Clamping Working Paper. So that it needs first repairs to these problems.

4. 6. 2. Line Balance Efficiency Process in the Production Sub-Process Assy Element Assy (End Plate A Plastisol, and End Plate B Macroplast Product)

From the data collection that has been done before , also it can be seen also the Each Process Workload in the Sub Process Production Assy Element Assy (End Plate A Plastisol, and End Plate B Macroplast) . And as for the distribution of Each Process Workload in the actual conditions can be seen in the following table:

No.	Work process	Operation Time	Idle Time	Station Efficiency
1	Process of Strut Clamping	4.96	1.51	76.66%
2	Plastisol Dispense Adhesive Process	3.50	2.97	54.10%
3	The Assy Process Between Element Paper, Double Flute, and End Plate A	4.64	1.83	71.72%
4	Process of Plastisol Oven Drying Adhesive	4.38	2.09	67.70%
5	Dispense Adhesive Macroplast to End Plate B Process	6.47	0.00	100.00%
6	Process Assy Element Assy Results From Previous Processes With End Plate B	4.20	2.27	64.91%
7	Press Process Element Assy and Macroplast Adhesive Drying Process	6.38	0.09	98.61%
8	The Process of Checking High Element Assy and Apply Packing B	4.39	2.08	67.85%
9	Element Assy Inkjet Process	1.17	5.30	18.08%
Total		40.09	18.14	

Table 8:- Division of Work Load on Product Sub Process Assy Element Assy (End Plate A Plastisol, and End Plate B Macroplast Product) Actual

And as for the calculation results on Line Balance Efficiency in the production process sub-process can be seen in the table below:

No.	Item	Measurement results
1	Idle Time	18.14 Seconds
2	Line Efficiency	68.85%
3	Balance Delay	31.15%
4	Smoothing Index	7.51

Table 9:- Resume Line Balance Efficiency on Product Sub Process Assy Element Assy (End Plate A Plastisol, and End Plate B Macroplast Product)

From Table 9 it can be seen that the Line Balance Efficiency level in the Sub Process of Production Assy Energy Assy (End Plate A Plastisol, and End Plate B Macroplast Product) can not be said to be good . This can be seen from there are still a number of work processes that have a larger cycle time than the Takt Time Production, which is the Working Process of Clamping Strut Paper , Macroplast to End Plate B Dispense Adhesive Process , and Press Element Assy and Macroplast Adhesive Drying Process . So that it needs first repairs to these problems.

4. 7. Process Capability

From the results of data collection that has been done on the Production Line Assy Element Assy, it can be seen that there are several work processes that still have low process capability. But for the sample case in this study, the focus of the research will be on the Plastisol Dispense Adhesive Process , which still has low process capability.

The Plastisol Dispense Adhesive process is the process of giving Plastisol Adhesive to the End Plate Element Assy Filter, both the Upper End Plate (End Plate A) and the Lower End Plate (End Plate B). A and the Critical Point is Plastisol Dispense Adhesive Process is Plastisol Adhesive Mass . Where Massa Adhesive associated with Vo lume Plastisol Plastisol Adhesive, which is closely den gan b erkaitan Filter filtration performance.

A sovereign, when Massa Adhesive Plastisol supplied does not match with Standard Massa Adhesive Plastisol, it will cause problems. If the Plastisol Adhesive Mass is less than the standard it will cause problems, such as: the binding strength of the End Plate against the Inner Liner and the Paper Media Filter which decreases or is not strong, leakage from the End Plate gap Element Assy that is not affected by Plastisol which causes Filter performance to decrease, etc. Whereas if the Plastisol Adhesive Mass is given too much, it will also cause problems, such as: Plastisol Adhesive will overflow during Process Assy, so it will contaminate the Paper Media Filter, which has an impact on decreasing the performance and appearance of the product. Besides the overflow of Plastisol Adhesive it will also pollute the Conveyor and Plastisol Hot Plate Adhesive Oven which will cause the End Plate Element Assy Filter to become dirty. Where as it is known that the dirty End Plate Element Assy Filter creates new jobs that are not actually needed, namely the process of cleaning Plastisol Adhesive which overflows and contaminates the outer side of the End Plate Element Assy Filter, both on End Plate A and End Plate B Element Assy Filter.

The process of Plastisol Dispense Adhesive is done using the Dispense Adhesive Plastisol Machine and Rotary Table. The description of the Plastisol Dispense Adhesive Process can be seen in the picture below:

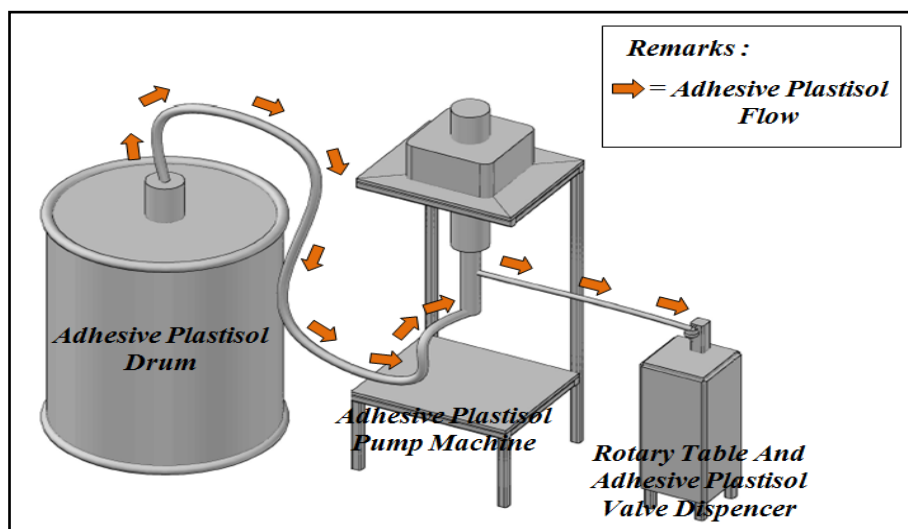

Fig 9:- Overview of Actual Plastisol Dispense Adhsive Process

From figure Figure 8 above, it can be seen that the Dispense Plastisol Process consists of two machines, namely:

- Plastisol Adhesive Pump Machine, which functions to suck Plastisol Adhesive from inside the Drum, and pump it into the Rotary Table Machine which has a Plastisol Adhesive Dispense Valve inside. The Plastisol Adhesive Pump is used using wind pressure.
- Rotary Table and Valve Dispense Adhesive Plastisol, which has the pouring function Plastisol Adhesive into the End Plate Filter.

In fact, two attempts have been made to improve the stability of the Plastisol Dispense Adhesive Process . The description of the initial improvements to the process capability in the Plastisol Adhesive Process are as follows:

- a. The initial conditions before the initial repairs are carried out, where the Drum distance and the Plastisol Adhesive Pump are very far away.

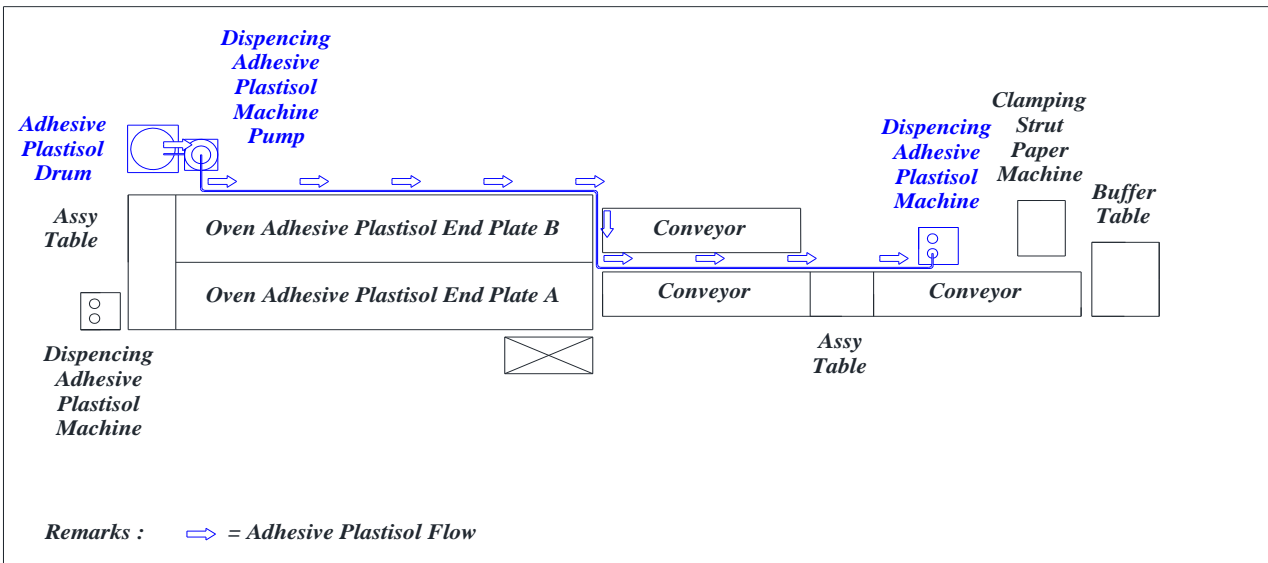

Fig 10:-Description of the initial condition of the D Process is Adhesive Plastisol before repair.

- b. Bring the Plastisol Adhesive Drum position and Plastisol Adhesive Pump Machine closer to the Rotary Table and Plastisol Valve Dispenser Machine.

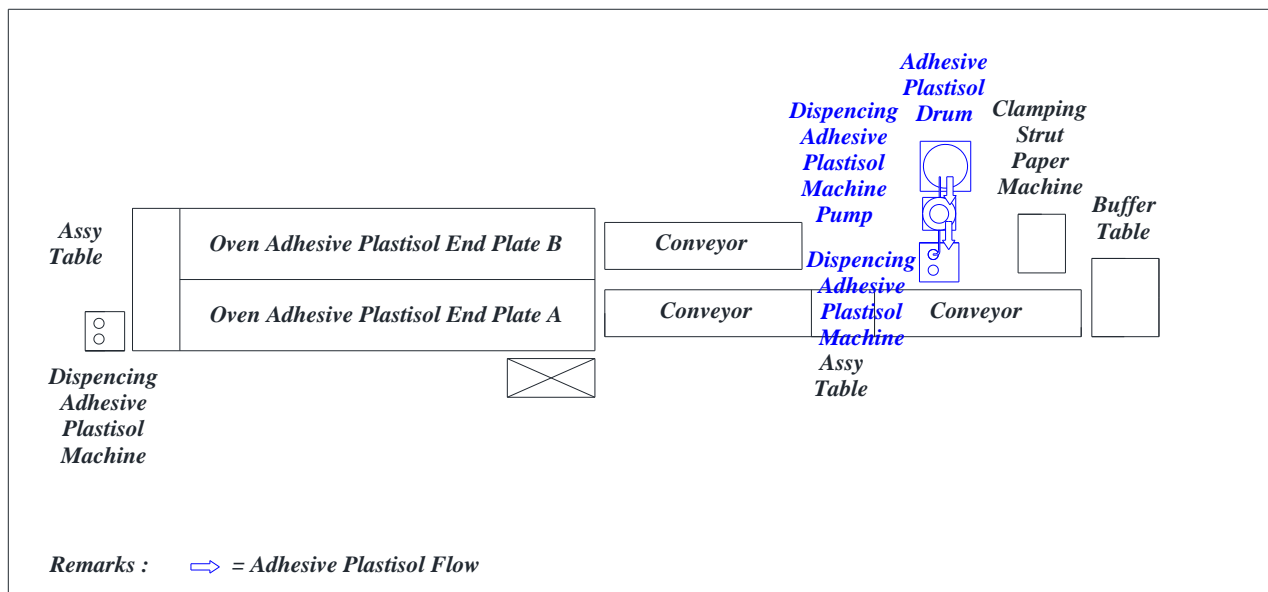

Figure 11:- An overview of the conditions of the first initial repair of the Dispense Adhesive Plastisol Process by bringing the position of the Plastisol Drum Drum and the Plastisol Adhesive Pump to close the Rotary Table and Adhesive Plastisol Valve Dispenser Machines.

c. Removing the Pump Engine Filter to facilitate the Plastisol Adhesive flow



Fig 12 :- An overview of the conditions for the initial improvement of both the Plastisol Dispense Adhesive Process by removing the Pump Machine Filter to facilitate the Plastisol Adhesive flow.

And as for the calculation results on Capability The process contained in the Dispense Adhesive Plastisol with these three conditions can be seen in the following table:

No.	Item	Standard	Actual Conditions		
			Conditions Before Initial Repair	Drum Conditions and Plastisol Adhesive Pump Machines Bring Into Near Rotary Table Machines and Plastisol Valve Dispencer Adhesive	Filter Conditions on the Plastisol Adhesive Pump Machine Removed
1	Plastisol Adhesive Mass	18.70 - 23.40 Gram	15.63 - 31.06 Gram	15.23 - 38.70 Gram	14.07 - 32.46 Gram
2	Plastisol Adhesive Mass Range	4.7 Gram	15.43 Gram	23.47 Gram	18.39 Gram
3	Cpk	1.33	-0.14	-0.25	-0.07
4	Cp	1.33	0.21	0.15	0.2
5	Sigma (σ) Level	4	-0.42	-0.76	-0.21
6	PPM Defect	6210	710688	825939	660477

Table 10:- Resume Capability Actual Plastisol Adhesive Dispense Process

Table 10 can be seen that the entire initial improvement at Adhesive Plastisol Process D ispense contained in the Production Line Assy Element Sub Area Assy Production Factory 2, PT. XYZ, has not been able to meet the Target Specifications Process set by the Company. So that other improvements are needed to the process of Plastisol Dispense Ad hesive, which aims that the problems arising from instability in the Plastisol Dispense Adhesive Process do not occur.

V. IMPROVEMENTS

5. 1. Improvements to Production Productivity

5. 1. 1. Improvement of Production Productivity P Sub Process Production Assy Element Assy (End Plate B Plastisol, and End Plate A Plastisol Product)

From Figure 5 found on the previous page it can be seen that there is one Work Operation in the Sub Production Process Assy Element Assy (End Plate B Plastisol, and End Plate A Plastisol Product) that have not been able to meet the Production Targets set by the Company, namely Working Process Clamping Strut Paper.

Process Clamping Strut Paper is the process of combining the ends of the stretch of the Paper Filter, to be like a tube to be able to proceed to the next sassy process. The description of the Strut Clamping Process can be seen in the picture below:

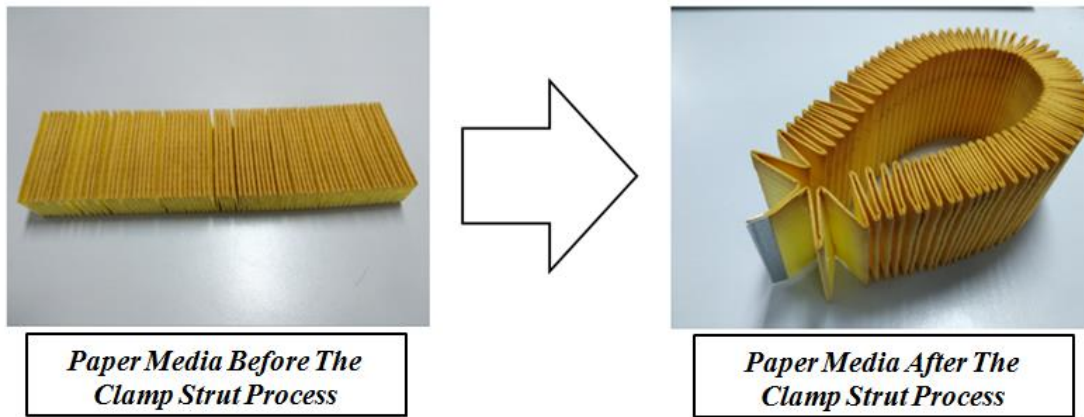

Fig 13:- Overview of Clamping Strut Paper Filter Process

In fact, there are two Work Operations contained in the Strut Clamping Process, namely Work Operations Cutting Paper Paths, and Work Operations Conducting Clamping Strut Paper Processes. As for the division of Work Operating Expenses in the Strut Clamping Poses can be seen in the picture below:

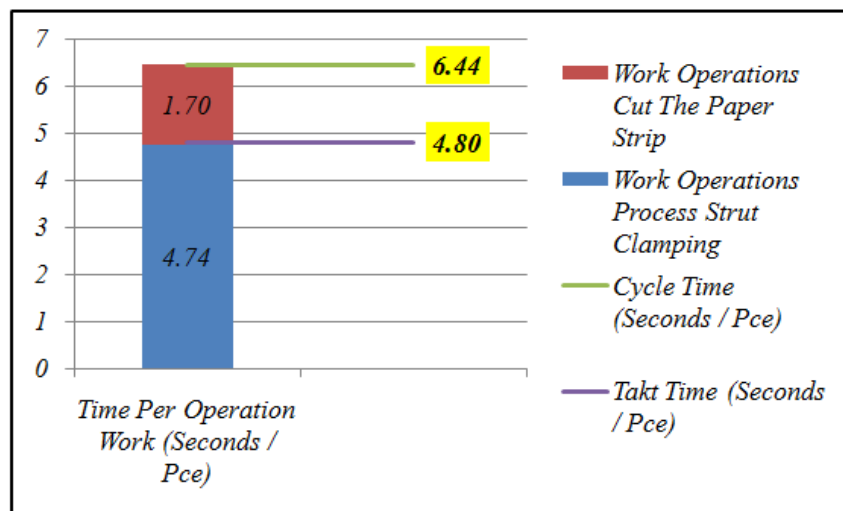

Fig 14:- Distribution of Work Operating Expenses in the Clamping Process of Strut Paper

From the game bar in Figure 14 above, it can be seen that if the Working Opposition to Cut the Paper Path is not done on the Sub Process Production Assy Element Assy (End Plate B Plastisol, and End Plate A Plastisol Product), it can reduce the Cycle Time in the process , and increase the overall Production Capacity in the Sub Production Process.

Based on this, the researchers tried to carry out the transfer of Operation Work Cutting the Paper Strip to Sub Production Line before Sub Production Line Assy Element Assy, namely Sub Production Line Component Element Paper (Element Paper Pleating) . And as for the relationship between the Sub Production Process Assy Element Assy (End Plate A Plastisol, and End Plate B Plastisol Product) and the Production Line Sub Component Paper (Element Paper Pleating) depicted on the OPC between the Production Sub-Line below:

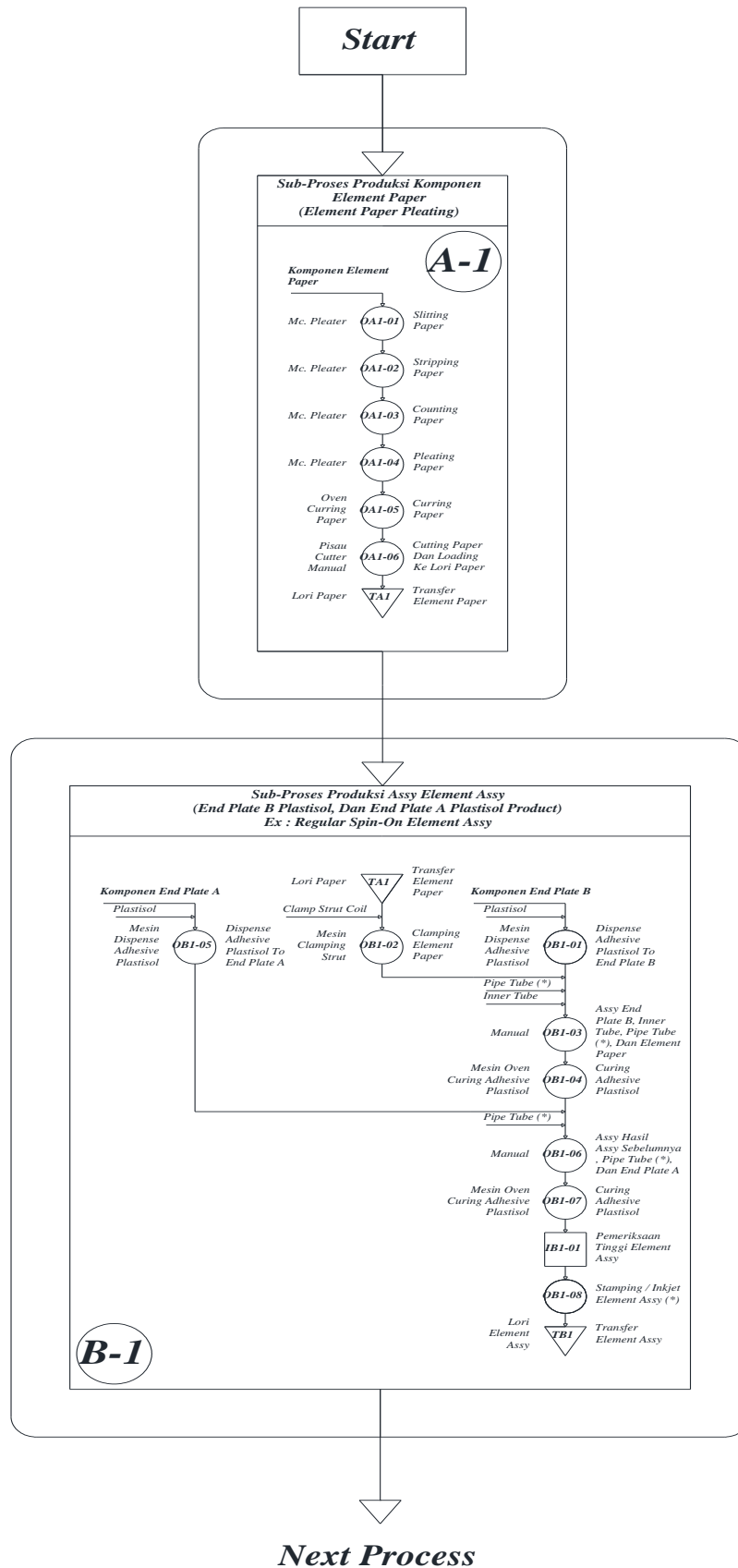

Fig 15:- Description of the relationship between the Sub Production Line Element Paper Pleating with the Sub Production Process Assy Element Assy (End Plate B Plastisol, and End Plate A Plastisol Product)

In actual conditions with 8 Hours of Work / Shift, the Production Sub Element Paper Paper (Element Paper Pleating) has not been able to meet the production target set by the Company, which is 15000 Pcs / Day. Based on this, the Element Paper Pleating Component Production Line is still diluted for 1 Hour / Shift to achieve the Production Capacity desired by the Company. The results of the calculation of the actual conditions of the Production Capacity with the Working Hours of 8 Hours / Shift and 9 Hours / Shift can be seen in the two tables below:

No.	Item	Time
A. Resume Working Time Measurement Results		
1	Set Up Time (Initial Production)	= 2456.87 Seconds ≈ 40.95 Minute
2	Change Over Time (COT)	= 1686.87 Seconds ≈ 28.11 Minute
3	Cycle Time (CT)	= 3.53 Seconds / Pcs
B. Production Target		
4	Production Target	= 300000 Pcs / Month ≈ 15000 Pcs / Day (20 Business Days) ≈ 7500 Pcs / Shift
C. Normal Working Time		
5	Normal Working Time (8 Hours)	= 8 Hour / Shift ≈ 480 Minute / Shift ≈ 28800 Seconds / Shift
D. Takt Time Production		
6	Takt Time Production	= 3.29 Seconds / Pcs
E. Change Over Time (COT)		
7	Jumlah Part Number Per Line Per Shift	= 2 Item / Line / Shift
8	COT Time Per Line Per Shift (2 Item / Line / Shift = 1 COT Time)	= 1686.87 Seconds / Line / Shift
F. Number of Production Lines		
9	Number of Production Lines	= 1 Production Line
G. Effective Working Time		
10	Effective Work Time	= 24656.26 Seconds / Shift ≈ 410.94 Minute / Shift ≈ 6.85 Hour / Shift
H. Actual Production Capacity		
11	Actual Production Capacity	= 6985 Pcs / Line / Shift
I. Actual Production Capacity VS target Production		
	Actual Production Capacity	= 6985 Pcs / Line / Shift
	Production Target	= 7500 Pcs / Shift
	Prod Capacity Difference Thp Target	= -515 Pcs / Line / Shift

Table 11:- Calculation of Productivity Level Production Sub Element Paper Paper Sub Element with 8 Hours of Work / Shift

No.	Item	Time
A. Resume Working Time Measurement Results		
1	Set Up Time (Initial Production)	= 2456.87 Seconds ≈ 40.95 Minute
2	Change Over Time (COT)	= 1686.87 Seconds ≈ 28.11 Minute
3	Cycle Time (CT)	= 3.53 Seconds / Pcs
B. Production Target		
4	Production Target	= 300000 Pcs / Month ≈ 15000 Pcs / Day (20 Business Days) ≈ 7500 Pcs / Shift
C. Normal Working Time		
5	Normal Working Time (8 Hours)	= 9 Hour / Shift ≈ 540 Minute / Shift ≈ 32400 Seconds / Shift
D. Takt Time Production		
6	Takt Time Production	= 3.77 Seconds / Pcs
E. Change Over Time (COT)		
7	Jumlah Part Number Per Line Per Shift	= 2 Item / Line / Shift
8	COT Time Per Line Per Shift (2 Item / Line / Shift = 1 COT Time)	= 1686.87 Seconds / Line / Shift
F. Number of Production Lines		
9	Number of Production Lines	= 1 Production Line
G. Effective Working Time		
10	Effective Work Time	= 28256.26 Seconds / Shift ≈ 470.94 Minute / Shift ≈ 7.85 Hour / Shift
H. Actual Production Capacity		
11	Actual Production Capacity	= 8005 Pcs / Line / Shift
I. Actual Production Capacity VS Production targets		
	Actual Production Capacity	= 8005 Pcs / Line / Shift
	Production Target	= 7500 Pcs / Shift
	<u>Prod Capacity Difference Thp Target</u>	= 505 Pcs / Line / Shift

Table 12:- Calculation of Productivity Levels of Production Sub Element Paper Paper (Element Paper Pleating) with 9 Hours of Work / Shift.

From the calculation of Actual Production Capacity against Table 11, and Table 12 it can be seen that Overtime for 1 Hour / Shift is still very much needed to achieve the predetermined Production Targets. Based on the previous, while gambaran of the relationship between Sub Line Component Production Element Paper (Element Paper Pleating) with Sub Production Process Assy Element Assy (End Plate B Plastisol, And End Plate A Plastisol Product) can be seen in the picture below :

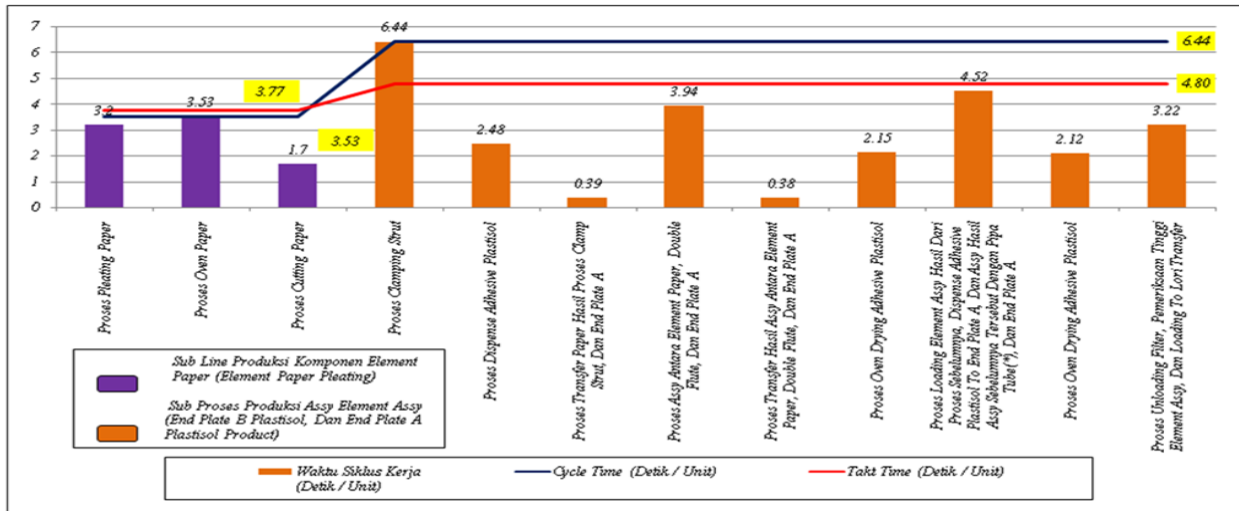

Fig 16:- Description of the relationship between the Sub Production Line Component Element Paper (Element Paper Pleating) with the Sub Production Process Assy Element Assy (End Plate B Plastisol, and End Plate A Plastisol Product) Actual

From the previous page it has been mentioned that the Work Operation of Cutting the Paper Strip is one of the causes of the decreasing level of Process Capability in the Sub Process of Production Assy Element Assy (End Plate B Plastisol, and End Plate A Plastisol Product) , based on this, the Workload on Work Operations it will be tried to be transferred to the Work Process in the Sub Production Line before the Sub Production Process Assy Element Assy (End Plate B Plastisol, and End Plate A Plastisol Product) , namely: Sub Production Line of Element Paper Pleating . And as for the results of the transfer of Workload can be seen in the graph and table below:

No.	Item	Time
A. Resume Working Time Measurement Results		
1	Set Up Time (Initial Production)	= 4471.38 Seconds ≈ 74.52 Minute
2	Change Over Time (COT)	= 313.74 Seconds ≈ 5.23 Minute
3	Cycle Time (CT)	= 4.74 Seconds / Pcs
B. Production Target		
4	Production Target	= 300000 Pcs / Month ≈ 15000 Pcs / Day (20 Business Days) ≈ 7500 Pcs / Shift
C. Normal Working Time		
5	Normal Working Time (8 Hours)	= 8 Hour / Shift ≈ 480 Minute / Shift ≈ 28800 Seconds / Shift
D. Takt Time Production		
6	Takt Time Production	= 4.80 Seconds / Pcs (3 Line Prod.) (2 Line Prod. In Shift 1, and 1 Line Prod. In Shift 2)
E. Change Over Time (COT)		
7	Number of Part Number Per Line Per Shift	= 2 Item / Line / Shift
8	COT Time Per Line Per Shift (2 Item / Line / Shift = 1 COT Time)	= 313.74 Seconds / Line / Shift
F. Number of Production Lines		
9	Number of Production Lines	= 3 Production Line / Day (2 Line Prod. In Shift 1, and 1 Line Prod. In Shift 2)

G. Effective Working Time			
10	Effective Work Time	=	24014.88 Seconds / Shift
		≈	400.25 Minute / Shift
		≈	6.67 Hour / Shift
H. Actual Production Capacity			
11	Actual Production Capacity	=	5066 Pcs / Line / Shift
I. Actual Production Capacity VS target Produ c			
	Actual Production Capacity	=	15199 Pcs / Day (3 Line Prod.)
	Production Target	=	15000 Pcs / Day
	Prod Capacity Difference Thp Target Target.	=	199.29 Pcs / Day

Table 13:- Results of Productivity Level Calculation Sub Production Line Assy Element Assy (End Plate B Plastisol, and End Plate A Plastisol Product) After P Repair

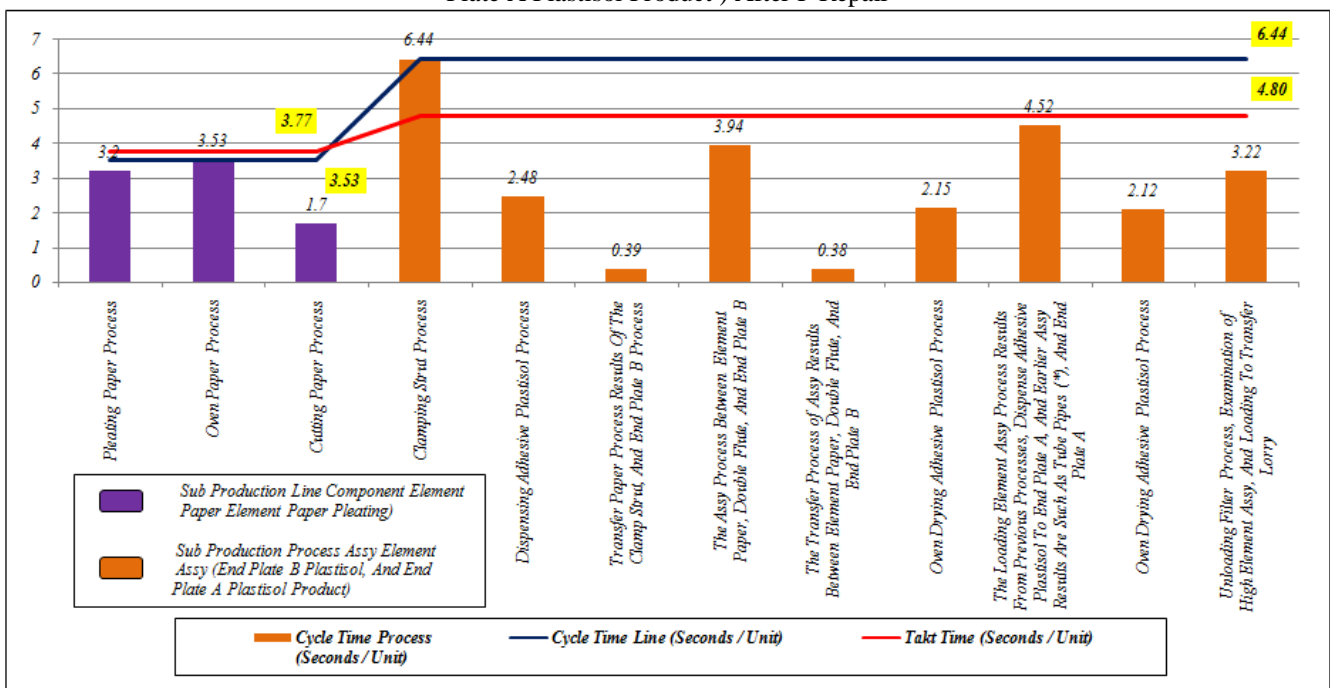

Fig 17:- The description of the relationship between the Sub Production Line Element Paper Pleating with the Sub Production Process Assy Element Assy (End Plate B Plastisol, and End Plate A Plastisol Product) after the process of transferring the Workload Process Cutting the Paper Strip to the Working Process of Cutting Paper in Sub Production Process Assy Element Assy (End Plate B Plastisol, And End Plate A Plastisol Product)

From these calculations may diskette is a hui that production capacity in Sub Production Process Assy Element Assy (End Plate B Plastisol, and End Plate A Plastisol Product) tersebu t been able to in achieving the target p roduction set by p ompany via load transfer k Gov Work Operations Cut the Paper Path to the Cutting Paper Work Process found in the Production Line of Element Paper Pleating Components . However, additional improvements need to be made to facilitate the Cutting Paper Working Process which is charged with the Scrolling Work Operation on the Paper Line. And while the additional improvements that still need to be done include:

1. Installing the Vacuum Slited Paper Vacuuming Machine on the Pleater Machine, in order to reduce the Cutting Paper Operator Workload.
2. Modifications to the Pressure Regulator installed on each of the blades Sliter, so that the pressure each Slitter Knives can be set separately, so memperm u dah Paper Cutting the operator work.

5. 1. 2. Improvements to Production Productivity in the Sub Process of Production of Assy Element Assy (End Plate A Plastisol, and End Plate B Macroplast Product)

From Figure 8 found on the previous page it can be seen that there are three problems found in the Sub Production Process Assy Element Assy (End Plate A Plastisol, and End Plate B Macroplast Product), which inhibits the achievement of Production Targets that have been set by the Company, namely : Strut Clamping Process, Macroplast Dispense Adhesive Process to End Plate B, and Press Process Element Assy and Macroplast Adhesive Drying Process . The improvements to these problems, namely:

a. Improvements to the Sikus Time Working Process of Strut Clamping

Improvements made to the Cycle Time Working Process Clamping Strut on the Sub-Production Process Assy Element Assy (End Plate A Plastisol, and End Plate B Macroplast Product) are the same as improvements made to the Cycle Process of the Strut Clamping Work performed on the Sub Production Process Assy Element Assy (End Plate B Plastisol, and End Plate A Plastisol Product), that is by moving the Operating Load Load Cutting Paper Strips in the Process of Clamping the Strut Paper in the Sub Production Process Assy Element Assy (End Plate A Plastisol, and End Plate B Macroplast Product) to the Cutting Paper Process that is in the Production Line Sub Element Paper Pleating .

Before carrying out the repair process, an evaluation of the Element Paper Pleating Component is evaluated first . From the results of calculations that have been done, in actual conditions with 8 Hours of Work / Shift, the Production Sub Element Paper Paper (Element Paper Pleating) has not been able to meet the Production Targets set by the Company, which is 15000 Pcs / Day. Based on this, the Element Paper Pleating Component Production Line is still diluted for 1 Hour / Shift to achieve the Production Capacity desired by the Company. The results of the calculation of the actual conditions of Production Capacity with 8 Hours / Shift and 9 Hours / Shift Working Hours can be seen in the two tables below:

No.	Item	Time
A. Resume Working Time Measurement Results		
1	Set Up Time (Initial Production)	= 2680.53 Seconds ≈ 44.68 Minute
2	Change Over Time (COT)	= 1953.53 Seconds ≈ 32.56 Minute
3	Cycle Time (CT)	= 3.58 Seconds / Pcs
B. Production Target		
4	Production Target	= 300000 Pcs / Bul an ≈ 15000 Pcs / Day (20 Business Days) ≈ 7500 Pcs / Shift
C. Normal Working Time		
5	Normal Working Time (8 Hours)	= 8 Hour / Shift ≈ 480 Minute / Shift ≈ 28800 Seconds / Shift
D. Takt Time Production		
6	Takt Time Pro duction	= 3.22 Seconds / Pcs
E. Change Over Time (COT)		
7	Number of Part Number Per Line Per Shift	= 2 Item / Line / Shift
8	COT Time Per Line Per Shift (2 Item / Line / Shift = 1 COT Time)	= 1953.53 Seconds / Line / Shift
F. Number of Production Lines		
9	Number of Production Lines	= 1 Production Line

G. Effective Working Time		
10	Effective Work Time	= 24165.94 Seconds / Shift ≈ 402.77 Minute / Shift ≈ 6.71 Hour / Shift
H. Actual Production Capacity		
11	Actual Production Capacity	= 6750 Pcs / Line / Shift
I. Actual Production Capacity VS target Production		
	Actual Production Capacity	= 6750 Pcs / Line / Shift
	Production Target	= 7500 Pcs / Shift
	Prod Capacity Difference Thp Target	= -750 Pcs / Line / Shift

Table 16:- Calculation of Productivity Level of Production Sub Element Paper Paper Sub Element (Element Paper Pleating) with 8 Hours of Work / Shift

No.	Item	Time
A. Resume Working Time Measurement Results		
1	Set Up Time (Initial Production)	= 2680.53 Seconds ≈ 44.68 Minute
2	Change Over Time (COT)	= 1953.53 Seconds ≈ 32.56 Minute
3	Cycle Time (CT)	= 3.58 Seconds / Pcs
B. Production Target		
4	Production Target	= 300000 Pcs / Month ≈ 15000 Pcs / Day (20 Business Days) ≈ 7500 Pcs / Shift
C. Normal Working Time		
5	Normal Working Time (8 Hours)	= 9 Hour / Shift ≈ 540 Minute / Shift ≈ 32400 Seconds / Shift
D. Takt Time Production		
6	Takt Time Production	= 3.70 Seconds / Pcs
E. Change Over Time (COT)		
7	Jumlah h Part Number Per Line Per Shift	= 2 Item / Line / Shift
8	COT Time Per Line Per Shift (2 Item / Line / Shift = 1 COT Time)	= 1953.53 Seconds / Line / Shift
F. Number of Production Lines		
9	Number of Production Lines	= 1 Production Line
G. Effective Working Time		
10	Effective Work Time	= 27765.94 Seconds / Shift ≈ 462.77 Minute / Shift ≈ 7.71 Hour / Shift

H. Actual Production Capacity			
11	Actual Production Capacity	=	7756 Pcs / Line / Shift
I. Actual Production Capacity VS target Production			
	Actual Production Capacity	=	7756 Pcs / Line / Shift
	Production Target	=	7500 Pcs / Shift
	Prod Capacity Difference Thp Target	=	256 Pcs / Line / Shift

Table 17:- Calculation of Productivity Levels of Production Sub Element Paper Paper (Element Paper Pleating) with 9 Working Hours / Shift

From the calculation of Actual Production Capacity for Table 16, and Table 17 it can be seen that Overtime for 1 Hour / Shift is still very much needed to achieve the predetermined Production Targets. Based on the previous thing too, as for the description of the relationship between the Sub Production Line Element Paper Pleating with the Product Sub-Process Assy Element Assy (End Plate A Plastisol, and End Plate B Macroplast Product) can be seen in the picture below this:

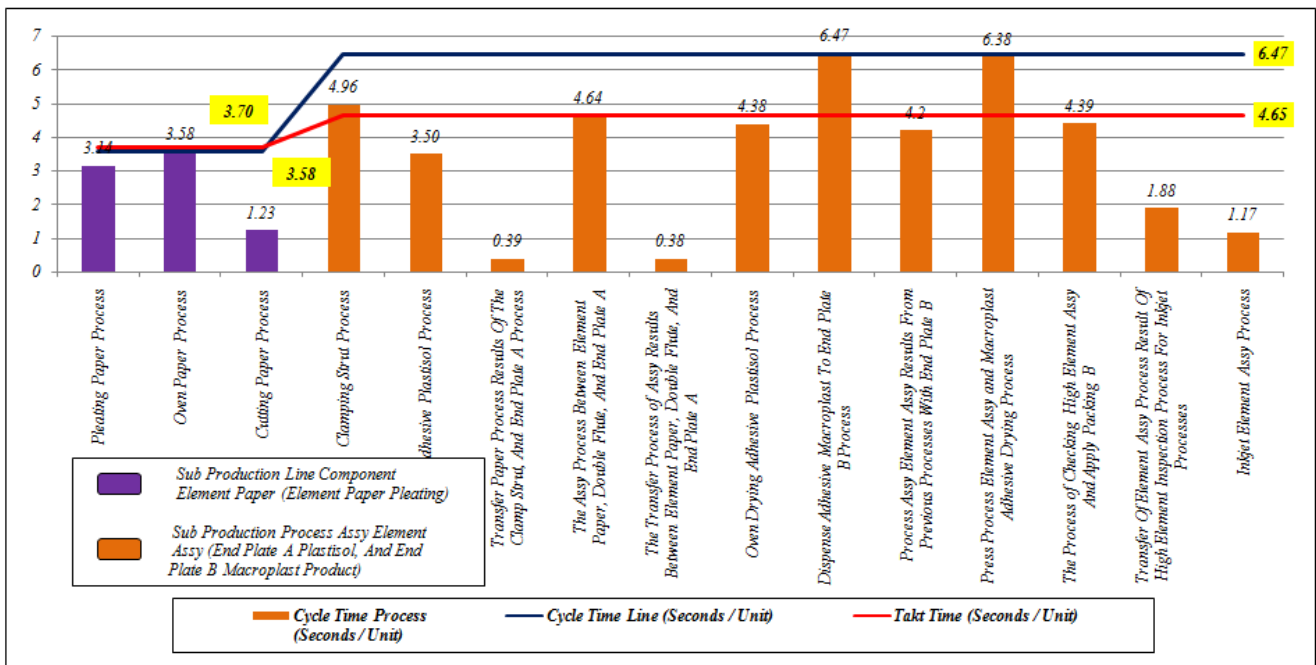

Fig 18:- Overview of the relationship between the Sub Production Line Element Paper Pleating with the Product Sub Process i Assy Element Assy (End Plate A Plastisol, and End Plate B Macroplast Product) Actual

Based on the foregoing, the improvement that will be carried out is by moving the Operating Expenses to Cut the Paper Strips in the Process of Clamping the Strut Paper in the Production Sub-Process Assy Element Assy (End Plate A Plastisol, and End Plate B Macroplast Product) to the Cutting Paper Process in the Sub Production Line of Element Paper Pleating Components. And as for the results of the process of moving the Operating Expenses to Cut the Paper Strip can be seen in the graph below:

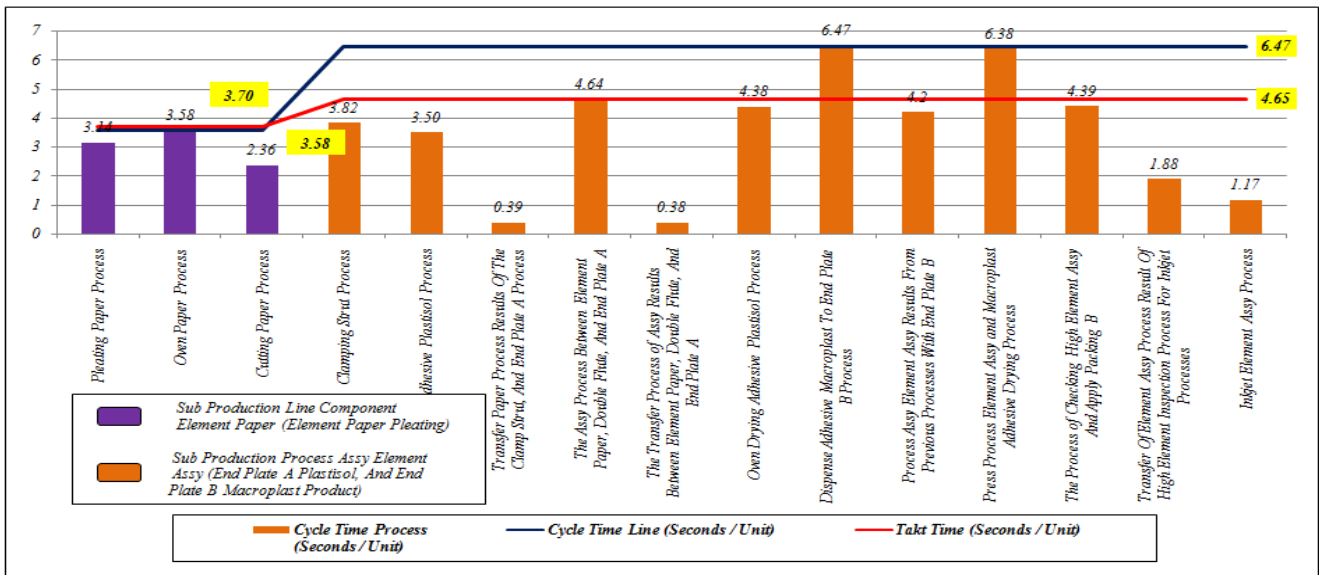

Fig 19:- Description of the relationship between the Production Line Sub Element Paper Pleating with the Production Sub-Process Assy Element Assy (End Plate A Plastisol, and End Plate B Macroplast Product) after the process of transferring the Workload The Process of Cutting the Paper Path to the Working Process of Cutting Paper in the Product Sub Process i Assy Element Assy (End Plate A Plastisol, and End Plate B Macroplast Product)

From these calculations, it can be seen that the Production Capacity in the Sub Production Process Assy Element Assy (End Plate A Plastisol, and End Plate B Macroplast Product) has been able to achieve the Production Targets set by the Company through the Workload Operating Work Transfers Cut the Paper Path to Cutting Paper Work Process in S ub Production Line Element Paper Pleating Components . But the same as the results of improvements made on the Sub Process Production Assy Element Assy (End Plate B Plastisol, and End Plate A Macroplast Product), things still need to be done additional improvements to facilitate the Working Process of Cutting Paper which is charged with the Operation Operation of Cutting the Paper Strip. And while the additional improvements that still need to be done include:

1. Installing the Vacuum Slited Paper Vacuuming Machine on the Pleater Machine, in order to reduce the Cutting Paper Operator Workload.
2. Modification by installing a Pressure Regulator on each of the Slitter Blades, so that the pressure of each Slitter Knife can be set separately, so that the Cutting Paper Operator works.

b. Improvement of Cycle Dispense Adhesive Macroplast to End Plate B Cycle Time

The Dispense Adhesive Macroplast process is carried out using two types of machines, namely: Mixer Machines and Macroplast Adhesive Dispensers, and Rotary Table Machines. The description of the two machines can be seen in the picture below:

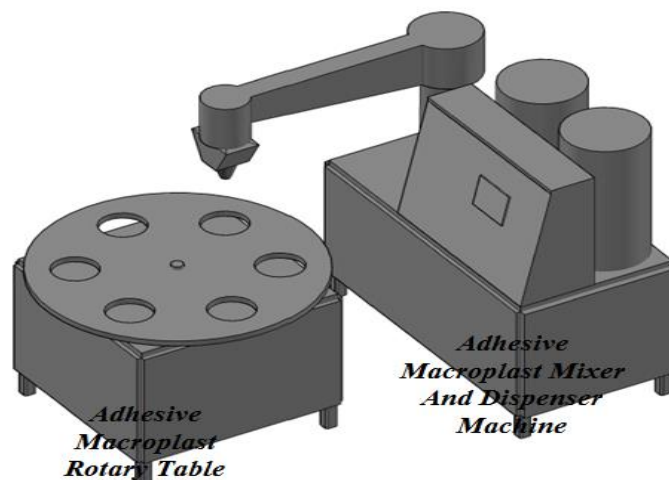

Fig 20:- Overview of Mixer Machines and Macroplast Adhesive Dispensers, and Rotary Table Machines

And as for the description of the Working Process of Macroplast Adhesive Dispense can be seen in the picture below:

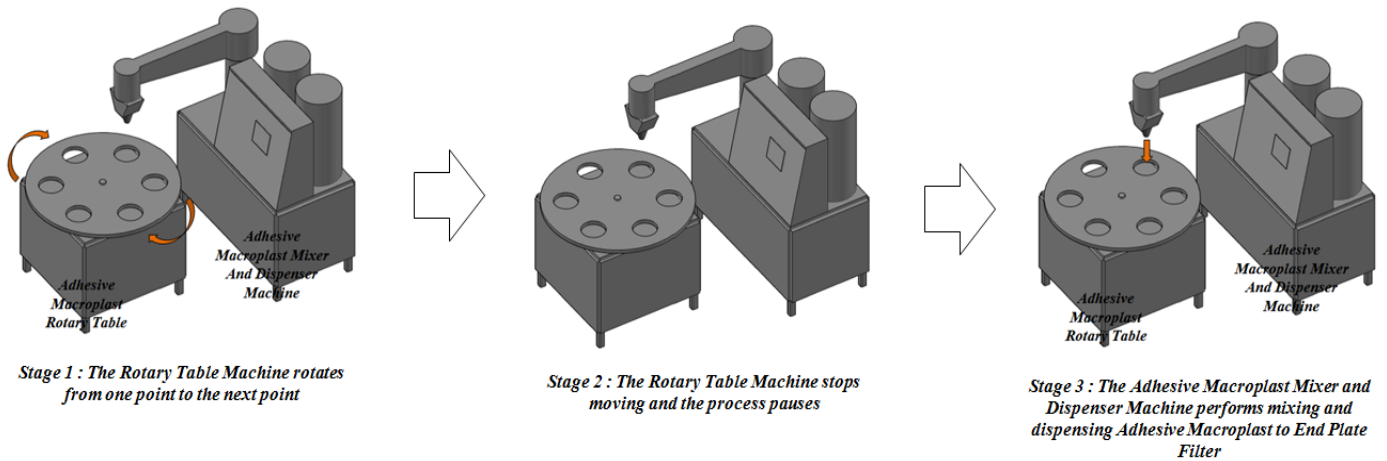

Fig 21:- Overview of the Work Process of Macroplast Dispense Adhesive on Mixer Machines and Macroplast Adhesive Dispensers, and Actual Rotary Table Machines

From the figure in Figure 18, we can see that there are three Work Operations in the Macroplast Dispense Adhesive Process, that the Rotary Table Machine rotates from one point to the next, the Rotary Table Machine stops rotating for a moment, and the Mixer and Dispense Adhesive Macroplast Machine Processes Mixing and Dispense Adhesive Macroplast to End Plate Filters. And as for the results of the measurement of the Work Operations contained in the Work Process of the actual Macroplast Dispense Adhesive can be seen in the following table:

No.	Work Operations	Machine	Operating Time (Seconds / Units)
1	Rotary Table Machines Rotate From Point to Point Next	Rotary Table Macroplast Adhesive Dispense Machine	1.25 Seconds / Units
2	The Rotary Table machine stops rotating for a moment	Macroplast Adhesive Dispense Machine	2.08 Seconds / Units
3	Macroplast Adhesive Mixing and Dispensing Process	Macroplast Adhesive Dispense Machine	3.14 seconds / unit
Total Work Process Time			6.47 seconds / unit

Table 18:- Work Operations contained in The actual process of Dispense Adhesive Macroplast

From Table 15 it can be seen that there is a potential improvement in Cycle Time in the Macroplast Dispense Adhesive Process, which is when the Rotary Table Machine stops rotating for a moment. The Rotary Table Machine Stop Spinning Momentarily is a Work Operation that is not needed in the Macroplast Dispense Adhesive Work Process, so that the Work Operation can be removed.

The improvements made to reduce the time when the Rotary Table Machine Stop Rotating for a moment is to change the parameters of the Rotary Table Machine from 4.5 Hz, to 2 Hz. So the Waiting Time in the Process is gone. The results of the measurement of the Work Operations contained in the Work Process of Macroplast Dispense Adhesive after the repair can be seen in the following figure and table:

No.	Work Operations	Machine	Operating Time (Seconds / Units)
1	Rotary Table Machines Rotate To End Plate Gauge Next	Rotary Table Macroplast Adhesive Dispense Machine	1.25 Seconds / Units
2	Macroplast Adhesive Mixing and Dispensing Process	Macroplast Adhesive Dispense Machine	3.14 seconds / unit
Total Work Process Time			4.39 Seconds / Units

Table 19:- Work Operations contained in Macroplast Dispense Adhesive Work Process after changing parameters of Rotary Table Machine settings

From Table 18, and Table 19, we can see that there are improvements in Cycle Time in the Work Process of Macroplast Adhesive Dispense. Changes in these parameters did not affect the stability of the Macroplast Adhesive Dispense Process,

because the Rotary Table Machine was accelerated only, in the Macroplast Adhesive Mixing and Dispensing Machine no parameter changes were made that could change the stability of the process.

c. Improvements to Press Process Cycle Time Element Assy and Macroplast Adhesive Drying Process

The process of improvement of Press Element Assy Cycle Time and Macroplast Drying Adhesive Process is carried out by accelerating the parameters of the "Z" Conveyor Machine. The comparison of the conditions before and after changing the parameters of the "Z" Conveyor Machine can be seen in the table below:

No.	Item	Initial conditions	Repair Conditions
1	Rotary Table Machine Speed Parameters	15.2 Hz	11.0 Hz
2	Machine Cycle Time	6.38 Seconds / Units	4.60 seconds / unit

Table 20:- Comparison of Cycle Times in the Elemental Press Process and Macroplast Drying Process that is carried out on a "Z" Conveyor Machine

d . Resume Results of Improvement on Production Productivity and Line Balance Efficiency in Sub Process Production of Assy Element Assy (End Plate A Plastisol, and End Plate B Macroplast Product)

From the results of the improvements that have been made, as for the description of the resumes the overall improvements that have been made can be seen in the table and graph below:

No.	Item	Time
A. Resume Working Time Measurement Results		
1	Set Up Time (Initial Production)	= 5219.08 Seconds ≈ 86.98 Minute
2	Change Over Time (COT)	= 312.87 Seconds ≈ 5.21 Minute
3	Cycle Time (CT)	= 4.64 Seconds / Pcs
B. Production Target		
4	Production Target	= 300000 Pcs / Month ≈ 15000 Pcs / Day (20 Business Days) ≈ 7500 Pcs / Shift
C. Normal Working Time		
5	Normal Working Time (8 Hours)	= 8 Hour / Shift ≈ 480 Minute / Shift ≈ 28800 Seconds / Shift
D. Takt Time Production		
6	Takt Time Production	= 4.65 Seconds / Pcs (3 Line Prod.) (2 Line Prod . In Shift 1, and 1 Line Prod. In Shift 2)
E. Change Over Time (COT)		
7	Number of Part Number Per Line Per Shift	= 2 Item / Line / Shift
8	COT Time Per Line Per Shift (2 Item / Line / Shift = 1 COT Time)	= 312.87 Seconds / Line / Shift
F. Number of Production Lines		
9	Number of Production Lines	= 3 Production Line / Day (2 Line Prod in Shift 1, and 1 Line Prod. In Shift 2)
G. Effective Working Time		

10	Effective Work Time	= 23268.05	Seconds / Shift
		≈ 387.80	Minute / Shift
		≈ 6.46	Hour / Shift
H. Actual Production Capacity			
11	Actual Production Capacity	= 5015	Pcs / Line / Shift
I. Actual Production Capacity VS target Production			
	Actual Production Capacity	= 15044	Pcs / Day (3 Line Prod.)
	Production Target	= 15000	Pcs / Day
	Prod Capacity Difference Thp Target	= 44.00	Pcs / Day

Table 21:- Productivity Level Calculation Results Sub Production Line Assy Element Assy (End Plate A Plastisol, and End Plate B Macroplast Product) after repairs

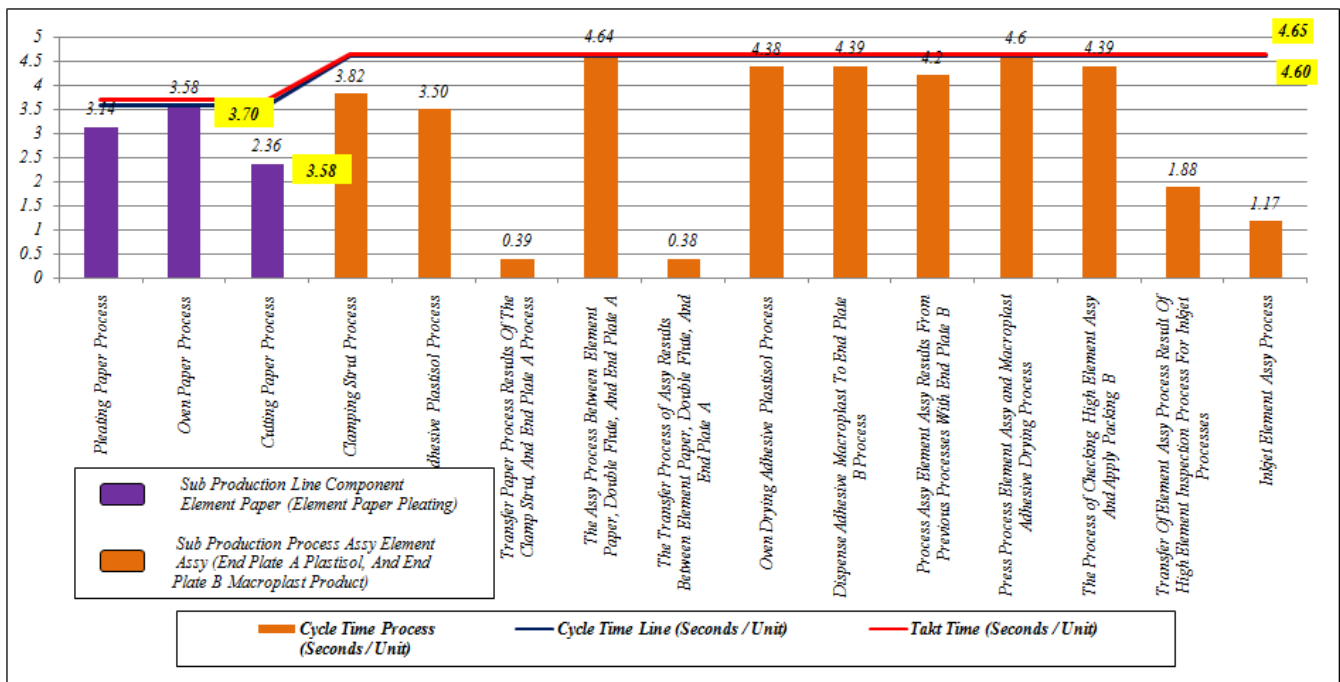

Fig 22:- Description of the relationship between the Sub Production Line Element Paper Pleating with the Sub Process Production of Assy Element Assy (End Plate A Plastisol, and End Plate B Macroplast Product) after repairs

From Table 19, and Figure 19 found on the previous page, it can be seen that the Production Capacity after the repair process has been able to meet the Production Targets set by the Company.

5. 2. Line Balance Efficiency Process Improvement Results

5. 2. 1. Line Balance Efficiency Process Improvement Results in the Production Sub-Process Assy Element Assy (Plastisol End Plate B, and End Plate A Plastisol Product).

From the results of calculations on the improvement of processes contained in the Sub-Production Process Assy Element Assy (End Plate B Plastisol, and End Plate A Plastisol Product) found on the previous page as for Line Balance Efficiency in Conditions After Repair can be seen in the table below:

No.	Work process	Operation Time	Idle Time	Station Efficiency
1	Process of Strut Clamping	4.74	0	100.00%
2	Plastisol Dispense Adhesive Process	2.48	2.26	52.32%
3	The Assy Process Between Element Paper, Double Flute, and End Plate A	3.94	0.8	83.12%
4	Process of Plastisol Oven Drying Adhesive	2.15	2.59	45.36%
5	The Loading Element Assy Process Results From Previous Processes, Plastisol To End Plate Dispense Adhesive, And Earlier Assy Results Are Such As Tube Pipes (*), And End Plate A.	4.52	0.22	95.36%
6	Process of Plastisol Oven Drying Adhesive	2.12	2.62	44.73%
7	Unloading Filter Process, Examination of High Element Assy, and Loading To Lori Transfer	3.22	1.52	67.93%
Total		23.17	10.01	

Table 14:- Division of Work Load on Product Sub Process Assy Element Assy (End Plate B Plastisol, and End Plate A Plastisol Product) after the repair process

And as for the calculation results on Line Balance Efficiency in the production process sub-process can be seen in the table below:

No.	Item	Measurement results
1	Idle Time	10.01 Seconds
2	Line Efficiency	69.83%
3	Balance Delay	30.17%
4	Smoothing Index	4.66

Table 15:- Resume Line Balance Efficiency on Product Sub Process Assy Element Assy (End Plate B Plastisol, and End Plate A Plastisol Product)

From the results of the conference, it can be seen that there is an improvement in Line Balance Efficiency in the Sub Production Process of the Element Assy.

5.2.2. Line Balance Efficiency in the Production Sub-Process Assy Element Assy (End Plate A Plastisol, and End Plate B Macroplast Product).

From the calculation results of the process improvements found in the Sub Production Process Assy Element Assy (End Plate A Plastisol, and End Plate B Macroplast Product) can be known the Line Balance Efficiency level in the Sub Production Process in the table below:

No.	Work process	Operation Time	Idle Time	Station Efficiency
1	Process of Strut Clamping	3.82	0.82	82.33%
2	Plastisol Dispense Adhesive Process	3.50	1.14	75.43%
3	The Assy Process Between Element Paper, Double Flute, and End Plate A	4.64	0.00	100.00%
4	Process of Plastisol Oven Drying Adhesive	4.38	0.26	94.40%
5	Dispense Adhesive Macroplast to End Plate B Process	4.39	0.25	94.61%
6	Process Assy Element Assy Results From Previous Processes With End Plate B	4.20	0.44	90.52%
7	Press Process Element Assy and Macroplast Adhesive Drying Process	4.60	0.04	99.14%
8	The Process of Checking High Element Assy and Apply Packing B	4.39	0.25	94.61%
9	Element Assy Inkjet Process	1.17	3.47	25.22%
Total		35.09	6.67	

Table 22:- Division of Work Load on Product Sub Process Assy Element Assy (End Plate A Plastisol, and End Plate B Macroplast Product) after the repair process

And as for the calculation results on Line Balance Efficiency in the production process sub-process can be seen in the table below:

No.	Item	Measurement results
1	Idle Time	6.67 Seconds
2	Line Efficiency	84.03%
3	Balance Delay	15.97%
4	Smoothing Index	3.79

Table 23:- Resume Line Balance Efficiency on Product Sub Process Assy Element Assy (End Plate A Plastisol, and End Plate B Macropalst Product)

5.3 . Capability Improvement Plastisol Dispense Adhesive Process

Based on Table 10 found on the previous page, it can be seen that the initial improvements that have been made have not had a positive impact on the capability of the Plastisol Adhesive Dispense Process , so that further improvements are needed . Based on these then an improvement is made by adding the Gear Pump to the Dispen Process of the Plastisol Adhesive. Gear Pump is part of the Macroplast Adhesive Mixer and Dispenser Machine which is used to flow Macroplast Adhesive from the Storage Tube to the Mixer Chamber inside the Macroplast Adhesive machine. Basically the Gear Pump has been used as one of the machines in the Plastisol Adhesive Dispense System in the Factory 1 Production Area, PT. XYZ, as an improvement plan for previous customer claims. The description of the working process of adding a Gear Pump to the Plastisol Dispense Adhesive Process can be seen in the picture below:

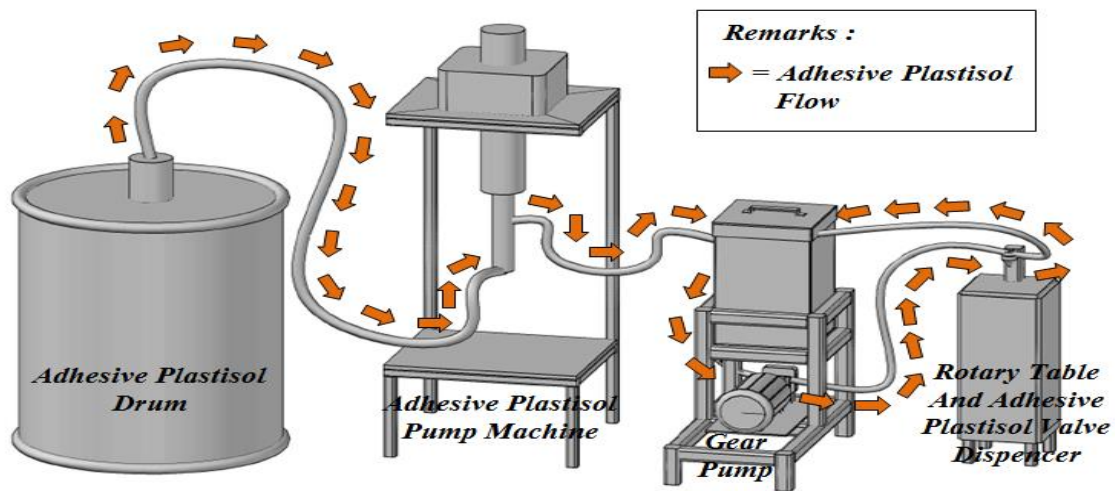

Fig 23:- Working Process Overview of the addition of the Gear Pump in the Plastisol Dispense Adhesive Process.

And as for the calculation results of the process capability in the Plastisol Adhesive Dispense Process after the addition of the Gear Pump can be seen in the table below:

No.	Item	Standard	Conditions After Repair
			Conditions After Applying a Gear Pump to the Plastisol Dispense Adhesive System
1	Plastisol Adhesive Mass	18.70 - 23.40 Gram	20.74 - 21.44 Gram
2	Plastisol Adhesive Mass Range	4.7 Gram	0.70 Gram
3	Cpk	1.33	3.52
4	Cp	1.33	3.56
5	Sigma (σ) Level	4	10.60
6	PPM Defect	6210	0

Table 24:- Resume Capability The Plastisol Dispense Adhesive Process After Repair

From the results of calculations on the capability of the above process, it can be seen that the Plastisol Adhesive Dispense Process under conditions after repair has been able to meet the Target Product Specifications that have been determined by the Company.

VI. 6. RESULT AND COMPARISON

6. 1. Result and Comparison Process Productivity in Initial Process Conditions and After Improvement of Production Sub-Process Assy Element Assy (End Plate B Plastisol, and End Plate A Plastisol Product)

The comparison of the initial conditions of the process, before the repairs are carried out, and the conditions that have been made to improve the process can be seen in the table below:

No.	Item	Initial Process Conditions	Conditions After Repair	Information
1	Production Target Per Day (Pcs / Day)	15000	15000	
	Production Capacity (Pcs / Day)	11187	15199	
	Production Capacity Difference Against Production Target (Pcs)	-3813 (Minus)	199.29	
2	Working Time To Meet Production Target (Hours)	13.5 (Overtime 5.5 Hours)	8	
3	Takt Time (Seconds / Pcs)	4.80	4.80	
	Cycle Time (Seconds / Pcs)	6.44	4.74	
4	Number of Production Lines Per Day (Line)	3	3	2 Line (Shift 1), and 1 Line (Shift 2)
Information		Not yet reached	Achieved	

Table 25:- Comparison of Production Productivity in Initial Process Conditions and Conditions After Improvement of Production Sub-Process Assy Element Assy (End Plate B Plastisol, and End Plate A Plastisol Product)

No.	Item	Initial Process Conditions	Conditions After Repair	Information
1	Line Balance Efficiency	55.17%	69.83%	
2	Balance Delay	44.83%	30.17%	
3	Idle Time	20.21	10.01	
4	Smoothing Index	8.55	4.66	
Information		Low	Increase	

Table 26:- Comparison of Line Balance Efficiency in the Initial Conditions of Processes and Conditions After Repairing the Sub Production Process Assy Element Assy (End Plate B Plastisol, and End Plate A Plastisol Product)

From Table 25, and Table 26 it can be seen that the process of improvement carried out on the Sub-Production Process of Assy Element Assy (End Plate B Plastisol, and End Plate A Plastisol Product) has a positive impact on Productivity Levels and Line Balance Efficiency on Sub Production Lines that is.

6. 2. Result and Comparison Process Productivity in Initial Process Conditions and After Improvement of Production Sub-Process Assy Element Assy (End Plate A Plastisol, and End Plate B Macroplast Product)

The comparison of the initial conditions of the process, before doing repairs, and conditions after the process improvement can be seen in the table below:

No.	Item	Initial Process Conditions	Conditions After Repair	Information
1	Production Target Per Day (Pcs / Day)	15000	15000	
	Production Capacity (Pcs / Day)	10789	15044	
	Production Capacity Difference Against Production Target (Pcs)	-4211 (Minus)	44	
2	Working Time To Meet Production Target (Hours)	13.5 (Overtime Hours)	5.5 8	
3	Takt Time (Seconds / Pcs)	4.65	4.65	
	Cycle Time (Seconds / Pcs)	6.47	4.64	
4	Number of Production Lines Per Day (Line)	3	3	2 Line (Shift 1), and 1 Line (Shift 2)
Information		Not yet reached	Achieved	

Table 27:- Comparison of Production Productivity in Initial Process Conditions and Conditions After Improvement of Production Sub-Process Assy Element Assy (End Plate A Plastisol, and End Plate B Macroplast Product)

No.	Item	Initial Process Conditions	Conditions After Repair	Information
1	Line Balance Efficiency	68.85%	84.03%	
2	Balance Delay	31.15%	15.97%	
3	Idle Time	18.14	6.67	
4	Smoothing Index	7.51	3.79	
Information		Low	Increase	

Table 28:- Comparison of Line Balance Efficiency in the Initial Conditions of Processes and Conditions After Repairing the Production Sub-Process Assy Element Assy (End Plate A Plastisol, and End Plate B Macroplast Product)

From Table 27, and Table 28, it can be seen that the repair process carried out on the Sub-Production Process Assy Element Assy (End Plate A Plastisol, and End Plate B Macroplast Product) has a positive impact on Productivity Levels and Line Balance Efficiency on Sub Production Lines that is.

6. 3. Result and Comparison of Process Capability in Initial Conditions and After Process Improvement Plastisol Dispense Adhesive in the Sub Production Process Assy Element Assy

The comparison of the initial conditions of the process, before doing repairs, and conditions after the process improvement can be seen in the table below:

No.	Item	Standard	Actual Conditions			Conditions After Repair
			Conditions Before Initial Repair	Drum Conditions and Plastisol Adhesive Pump Machines Bring Into Near Rotary Table Machines and Plastisol Valve Dispencer Adhesive	Filter Conditions on the Plastisol Adhesive Pump Machine Removed	Conditions After Application Gear Pump in the Plastisol Dispense Adhesive System
1	Plastisol Adhesive Mass	18.70 - 23.40 Gram	15.63 - 31.06 Gram	15.23 - 38.70 Gram	14.07 - 32.46 Gram	20.74 - 21.44 Gram
2	Plastisol Adhesive Mass Range	4.7 Gram	15.43 Gram	23.47 Gram	18.39 Gram	0.70 Gram
3	Cpk	1.33	-0.14	-0.25	-0.07	3.52
4	Cp	1.33	0.21	0.15	0.2	3.56
5	Sigm a (σ) Level	4	-0.42	-0.76	-0.21	10.60
6	PPM Defect	6210	710688	825939	660477	0

Table 29:- Comparison of Capability of Plastisol Dispense Adhesive Process in Initial Conditions and After After Repair

From Table 29 it can be seen that, the process of improving the stability of the Plastisol Dispense Adhesive Process, which is carried out through the application of the Gear Pump in the Plastisol Adhesive dispense system, has been effective. This can be seen from the results of the measurement of process capability in the conditions after the improvements that have been in accordance with the standards to be achieved by the Company.

VII. CONCLUSIONS AND RECOMMENDATIONS

7.1. Conclusion

The growth of product demand from customers also requires the company to continue to grow. In addition to improvements berkesinambungan, preparation of pre-mass production, as a result of the expansion of the company, should be very concerned, both in terms of completeness of tooling production, examination preparation capabilities of the machine, the preparation of the calculation of the capacity of the machine, the preparation of setting man power, preparation in terms of the standards process produksi, etc. By doing pre-production preparation, it is expected that all potential problems can be identified earlier, so that they can prevent the occurrence of major problems when the mass production process takes place.

As for one example of this problem is excessive overtime which results in a large cost overtime, which is caused by the existing Production Target not in accordance with the existing Production Capacity. In addition to having an impact on the large cost overtime, the mismatch can also have an impact on the quality of the product being produced, namely the greater potential for human error that causes defective products. This is due to the gap between Production Targets and Production Capacity, so that Production Operators work in a hurry, ignoring "human factors", which can cause process errors, or in other words the process becomes uncontrolled.

Based on this, it can be concluded that continuous improvement is a systemic improvement, taking into account many factors in its implementation, so that the results of these improvements can actually be used and implemented in the field, and do not cause overlapping problems from various sides.

7.2. Suggestions

From the results of data processing can take several conclusions that can be used as a suggestion based on the management system existing quality, namely:

➤ Control of the production process carried out through continuous improvement and through pre-mass production preparation is a very vital thing for the company. It is intended that the process is in a prime position, and is controlled, so that all potential problems that can arise when mass production takes place, can be known in advance, and does not become a big problem in the future. In addition to the preparation stage of mass production, controlling the production process

should be evaluated regularly, so that the production process conditions are always in prime condition, both in terms of production capacity, and in terms of process capability that has a contribution to the quality of the products produced.

- In some companies that are make to order like PT. XYZ, where variations in manufactured products is very diverse, process control can d i started to make a mapping variations in the process, through a classification process based on common production process through which the process flow. It is intended that process control can be carried out more concisely, but does not reduce the level of effectiveness of the process of controlling the process. This is because not all product production processes are measured in terms of capacity and capability, but only a number of product samples that are considered to represent a particular group of processes. The principle of classifying the process can be re-accurate through the process of reducing the range of product variations within a particular process group. Or in other words, the finer the range of product variations in a particular process group, the data obtained will be closer to the real system in the field. As for one example of this is the Sub Production Process Assy Element Assy (End Plate B Plastisol, and End Plate A Plastisol Product), whose variations are refined into several categories, such as: Sub Production Process Assy Element Assy (End Plate B Plastisol, and End Plate A Plastisol Product) For Small End Plate Diameter (Adhesive Mass 9 - 20 Gram), Sub Production Process Assy Element Assy (End Plate B Plastisol, and End Plate A Plastisol Product) For Medium End Plate Diameter (Adhesive Mass 20 - 30 Gram), and Sub Production Process Assy Element Assy (Plastisol End Plate B, and End Plate A Plastisol Product) For Large End Plate Diameters (Adhesive Masses 30-40 Grams). In this case the Adhesive Plastisol Mass is perpendicular to the Diameter of the End Plate Element Assy Filter.
- Improvements that must be carried out must include consideration in all aspects so that the improvements made can really be implemented in the field, without any obstacles. And as for the basic principle of improvement that is done is to maximize the existing process. But a sovereign, when the work process has reached the maximum point process, so it can not or difficult to be redeveloped, then the improvement is to do with the development of the process of working through other methods. It aims to keep repair costs always low, with the impact of major repairs.
- As the pr i nsip base of improvement, process standardization is one of the things at crucial. It is intended that the improvements made to a problem can be completely completed, not only for a machine, but for all similar machines, especially for companies that have multiple Production Lines, so that there are no recurring problems in the future. So that the progress of the improvements made will be felt gradually. Based on this, there are additional notes on the issue, namely pen y eragaman machine used, it may be useful in

facilitating the repair work, and simplify the stock of replacement parts (spare parts) in Maintenance.

REFERENCES

- [1]. Rengganis, E. 2015. Comparison of Optimization Re-Layout Placement of Production Facilities Using Craft to Minimize Material Handling Costs. *Space Journal*.
- [2]. Lim bong, Inggried. 2013. Management of Procurement of Building Materials Using the MRP (Material Requirement Planning) Method Case Study: Revitalization of the North Sulawesi Provincial BPS Office Building. *Static Civil Journal. Volume 1 No 6*.
- [3]. Kashkoush, M., El Maraghy, H. 2015. Product Family Formation By Matching Bill-Of-Materials Trees. *Elsevier Journal. CIRP Journal of Manufacturing Science and Technology. CIRPJ-339; No. Of Pages 13. <http://dx.doi.org/10.1016/j.cirpj.2015.09.004>*.
- [4]. Thi Lam, N., Minh Toi, L., Thi Thanh Tuyen, V., & Ngoc Hien, D. 2016. Lean Line Balancing For An Electronics Assembly Line. *Elsevier Journal. Procedia CIRP 40 (2016) 437 - 442*.
- [5]. Dolgui, A., Gavarov, E. 2017. Some New Ideas For Assembly Line Balancing Research. *Elsevier Journal. IFAC PapersOnLine 50-1 (2017) 2255-2259. <https://doi.org/10.1016/j.ifacol.2017.08.189>*.
- [6]. Schmidt, R, L., Pearson, L, N., 2019. Is Your Assay Stable? Using Process Stability And Capability To Evaluate Assay Performance. *Elsevier Journal. Clinica Chimica Acta 490 (2019) 28–33. <https://doi.org/10.1016/j.cca.2018.12.015>*.